

the PowerRouter
you're in charge

Technical Specification

PowerRouter



Content

1. General	3
2. Functional requirements	4
3. AC/DC Module	7
3.1 AC/DC Module (general).....	7
3.2 Inverter mode (off-grid, stand alone, generator support)	7
3.3 Inverter mode (grid connected).....	8
3.3 Inverter mode (UPS)	8
3.4 Charger	8
4. Battery module	9
4.1 Battery moduel (general)	9
4.2 Battery module (charge mode)	9
4.3 Battery module (discharge mode).....	10
5. Solar module	10
6. Wind module	10
6.1 Generator	10
6.2 Wind module (generator mode).....	11
7. Display	11
8. Mechanical / Enclosure	11
8.1 Connections	11
8.2 Enclosure	12
8.3 Packaging	12
8.4 Environment & Certification	12

1. General

Definitions

Grid	Electric power system provided and supplied by the utilities, distributed by public means.
Off grid	Generate electric power locally, not widely distributed.
Grid connected inverter	Feeds generated energy back to the grid
Off-grid inverter	Builds a local grid.
PowerRouter module	Hard- and software module performing a dedicated function in the PowerRouter concept.
UPS	Un-interruptable power supply
PV	Photo-Voltaic
Shading	Indicates pending or need to be checked.
Islanding	Building a local grid
No load	only μ processor activity. Module is off.
Stand by	Internal 400Vdc bus is active, ready to function.
Search mode	μ processor is active, internal 400Vdc bus is powered periodically. When load is detected, the system is switched on.
MPP	Maximum Power Point. Point on the V-I curve of a PV panel which generates maximum power.

Product philosophy

The PowerRouter technology is a single phase modular power electronics platform for the conversion, storage and management of electrical energy. Each module performs its specific task as described in this document and is interconnected via a patented internal 400Vdc bus and CAN interface.

The system can supply energy back to the grid, improve grid quality and support weak grids build by e.g. generators. When grid fails, the system disconnects from the grid and builds a local grid. Switch-over time is suitable for UPS application. Supplied energy can be generated by connected PV panels, wind generator and/or stored energy in batteries. Batteries are charged either from the grid, external generator, solar or wind.

Typical applications are:

- on- or off grid solar inverter, optional with battery back-up
- grid connected wind inverter
- on- or off grid hybrid energy systems (generation by wind- and solar, storage in batteries)
- off-grid inverters (marine, mobile applications)
- on- or off grid combi (charger and inverter combined for marine and mobile applications)

2. Functional requirements

The PowerRouter system can be configured from several modules, performing different functions.

- On- or off grid solar inverter (AC/DC module + Solar module)
Converts connected solar energy and feeds it back to the grid, or builds a local grid
- Grid connected wind inverter (AC/DC module + Windmodule)
Converts connected solar energy and feeds it back to the grid
- On- or off grid hybrid energy systems (AC/DC-, + Solar-, + wind-, + battery module)
Converts connected solar and wind energy and feeds it back to the grid, or builds a local grid. A surplus of energy is stored in the connected batteries)
- Off-grid inverters (AC/DC-, + battery module)
Builds a local grid from energy stored in the batteries. Batteries are charged by separate battery charger
- On- or off grid combi (AC/DC-, battery module)
Converts stored energy and feeds it back to the grid, builds a local grid or supports a grid. Batteries are charged when grid is available
- On- or off grid solar inverter with battery back-up (AC/DC-, Solar-, and battery module)
The solar back-up is installed in parallel to an existing grid connected solar inverter. All power generated by the existing photovoltaic installation continues to be fed back to the grid normally (fig. 1); or
The solar back-up is connected between the grid and the load that needs to remain energized (UPS load). In normal condition the UPS load is supplied from the grid. The batteries are charged by the grid (fig. 2)
In case of grid failure, the grid connected inverter switches off and the solar back-up unit takes over the energy supply to the UPS load.

Whenever grid power is not available, the UPS load will be fed by solar power. If the connected solar string cannot deliver enough power, then the stored energy from the batteries is also used. In case more solar power is produced than the UPS load needs, the surplus will be stored in the batteries.

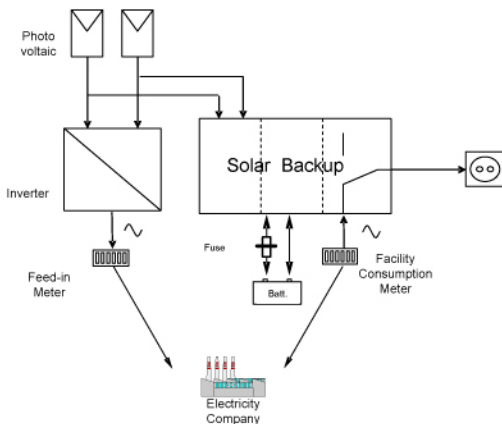

Fig. 1

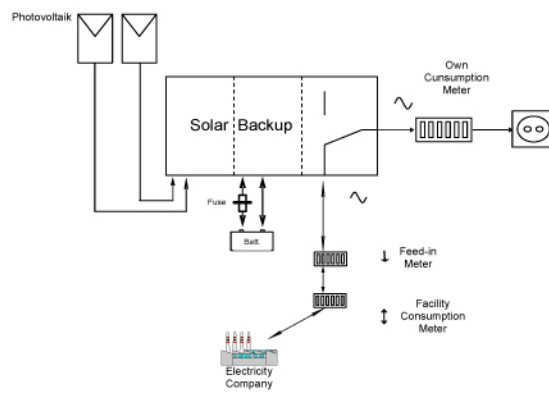

Fig. 2

Battery management will provide optimal charging characteristics for different type of batteries and will prevent batteries from misuse. Back-up time is calculated based on state of charge of the battery and the solar radiation.

the PowerRouter

you're in charge

User interface by incorporated LCD and interfaces will provide system information and allows system setting changes.

Function "Charger only" keeps batteries in shape and protects them from damage. No back-up function in this state.

Power Backbone Technology

The patented **Power Backbone technology** of Nedap s PowerRouter allows energy sources, storage media and loads to interchange energy and data. Nedap s PowerRouter may consist of several modules: an AC/DC module, battery module and input modules, each performing a specific function. All modules in a combined enclosure and may be extended with additional sources or storage functions. The generation part of the backbone may be a 5KW solar string, wind inverter, generator or any future renewable energy source. At high efficiency it converts the generated energy from wind or solar into to power backbone voltage (400Vdc). For safety reasons the generating modules are insulated from the grid, the loads and the batteries. The battery module uses the available energy on the power backbone to charge a battery bank. Since it is bi-directional, stored energy can be converted back to the power backbone.

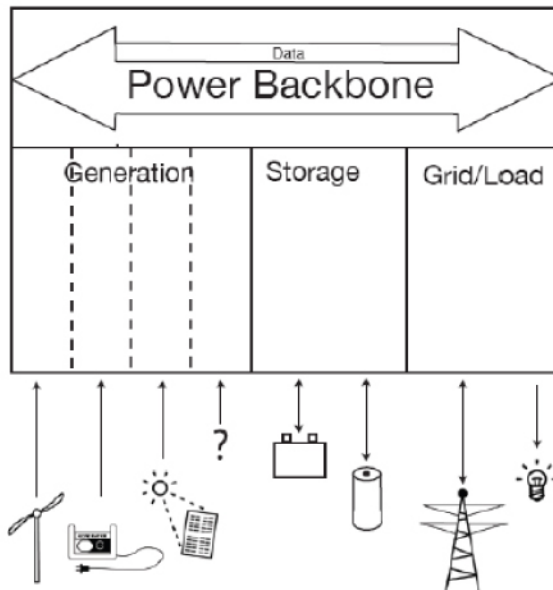

Versatile Technology

The AC/DC module is bi-directional. It may feed the energy of the power backbone to the grid or to an offgrid load. As a fully grid connected inverter, it is provided with a state-of-the-art anti-islanding protection. Even when the grid is disconnected or disrupted for an extended period of time, it will continue feeding the loads off-grid. The switchover is within 20msec. making it so fast it is unnoticeable to any user. The energy consumed from the grid is fed directly to attached loads or is used to charge the battery bank.

The power backbone allows the user to independently manage their energy supply and demand.

Generate Cash for Energy

When solar energy is available, it can be fed into the grid, thus generating money via the feed-in tariff. It can also be used to supply energy to a connecting load and any surplus energy is fed back to the grid, or is used to charge the battery. When solar is not sufficient, then battery power, and finally grid power will be used to keep the load energized. In the event that the grid fails, then solar and battery power will be directly utilized to continue to power the loads.

the PowerRouter

you're in charge

Uninterrupted Power Supply

These same features are also applicable for off-grid applications. The loads remain energized by using solar and/or wind energy directly and any surplus is used to charge the batteries. When sun and/or wind energy are not sufficient to charge the loads, additional energy is supplied by the batteries. In the case all sources are depleted, a signal is available to activate an external generator. These features guarantee a 24 hour per day supply of energy.

Modular System

You may configure your system out of a combination of a wind input module, a solar module, a battery module and the AC/DC module. Your initial system can be extended in the future with additional modules for future renewable energy sources and energy storage media. The power backbone makes sure the power is routed when and where you want it.

Technical requirements modules

3. AC/DC Module

3.1 AC/DC Module (general)

Efficiency	> 96%
No load power consumption	< 18W
Stand by power consumption	< 2W
Search mode	Output down, start up cycles, max 10 within 3 minutes. Switch off after 10 times with a manual reset by using the on-off switch
Leakage current	< 3.5mA
Protection class	1. (grounded)

3.1.1 Relay contacts and alarm levels

When trip conditions are met at the AC/DC module or battery module, the contact of a potential free relay contacts may switch over. E.g. to start a generator or give an external (audible) alarm.

Multi purpose relay	2, NO/NC, user adjustable, 250 Vac, 1 A; 24 Vdc, 5 A
Battery condition relay activation voltage	Dynamic, load dependable. Off: 18 - 22,0 Vdc, adjustable per 0.5 Vdc; 0 - 30 sec. delay (-mV/A). default 22 Vdc, delay: 10 sec.
Battery condition relay de-activation voltage	Voff + 2 Vdc. 24 – 26Vdc, adjustable per 0.5 Vdc, ; 0 - 30 sec. delay. Default 24V dc, delay: 10 sec.
AC condition relay activation voltage	Off low: 180 – 215Vac (default 180V); Off high 235 – 265 Vac (default 235V); delay Adjustable delay per 1 sec. Default 5 sec.
AC condition relay de-activation voltage	on low: 215 – 230Vac (default 215V); on high 230 - 235 Vac (default 235V); Adjustable delay per 1 sec. Default 5 sec.

3.2 Inverter mode (off-grid, stand alone, generator support)

Builds a grid, or functions parallel to a generator or grid. Neutral of the AC output can optionally be grounded for external ground fault circuit interrupter functionality. Supports a generator or grid when weak, and disconnects from the generator when source is outside the set voltage limits and continues as off-grid inverter. (Does not feed back to the grid)

Output Voltage (Unom)	230 or 240Vac Vac $\pm 2\%$ default, 180V to 254Vac, single phase
Frequency	50 Hz $\pm 0.2\%$
Output wave	True sine wave, max. 5% distortion
Continuous Output Power (up to Tnom)	5000VA, Cos phi = 1 at 5000W. (Pnom)
Load power factor	$0 < \cos \phi \leq 1$
Peak power (@ Unom.(1))	2 x Pnom, 5 sec. (2)
Max. nominal ambient temperature (Tnom)	40 °C
Derating above 40°C	500VA/°C (blinking LED)
Switch off temperature	50 °C (burning LED)
Generator / Grid Support	180 – 265Vac, 4 – 25A, 45 – 55 Hz
AC overload protection	Max. 40A(> 5 sec. @ Uout \geq Ulow), drops before switching -off
AC output short circuit protection	Max. 40A (< 5 sec, @ Uout < Ulow) + 2 x 30A fuses (slow blow)
Multiple module operation	Parallel switching; 3-phase switching
Grounding relay	NO, programmable
Isolation resistance detection	Yes, < 50kOhm, programmable

(1) Provided energy supply of sun- and/or battery module is sufficient.

(2) Output voltage may be non-sinusoidal

3.3 Inverter mode (grid connected)

Supplies energy back to the grid. Supports the grid or generator when weak, and disconnects from the grid when source is outside the set voltage limits and continues as off-grid inverter. Incorporated anti-islanding protection.

Output Voltage	180V to 265Vac; limited by anti-islanding requirements
Frequency	45 – 55 Hz; limited by anti-islanding requirements
Continuous Output Power (up to Tnom)	Max. 5000W
Anti- islanding protection	VDE 0126.1, G83/1, IEEE929. Further country specific requirements are under considerations. See separate document DOC00XXX for detailed requirements.
Disconnect device / back-feed relays	Mechanical, contact distance ≥ 3.2 mm

3.3 Inverter mode (UPS)

Continues feeding energy to a connected load when the grid fails.

Switch over time (UPS mode)	≤ 20 mSec.
Switch over time (search mode)	1 sec.
AC backfeed protection (ground fault)	Switch off < 3.5mA within 1 sec.

3.4 Charger

Energy is supplied by the grid or generator and transferred to the battery module

Input voltage	180 – 254 Vac
frequency	45 - 55 Hz
Input current (nominal)	15A (1)
Power factor (cos phi)	≥ 0.9

(1) Limited by software to fit 16A branch fuse

4. Battery module

4.1 Battery moduel (general)

Efficiency (@nominal power)	≥ 96%
No load consumption	< 18W
Stand by consumption	< 2W
Galvanic Separation	Yes

4.2 Battery module (charge mode)

Connected batteries are charged either by float charging (UPS application) or adaptive 3-stage charger for cyclic charging. For cyclic charging additional battery voltage sense wires and temperature sensor are required (not included). In case of overcharge, an alarm can be generated by the free contacts on the AC module. Battery output is protected against short circuit. Miswiring is detected, however, charger may be damaged afterwards. Batteries need to be protected against short circuit by separate fuse (not included).

Battery Voltage output Range (Vout)	18 – 32 Vdc
Ripple voltage (rms)	± 2% Vout
Output Charge Current	30 - 125 A dc continuous; default 125A
Ripple current	Max. 20% pp (LF)
battery capacity	Min. 150 Ah, at 30 A charge current.
Charging curve (float)	25.6 – 27.6 Vdc (wet), 26.4 – 28.4 Vdc (gel)
Charging curve (cyclic) (requires optional temp. sensor)	Adaptive 3-stage + maintenance charge

Bulk voltage	28 – 29.2 Vdc
Absorption voltage	28 – 29.2 Vdc
Float voltage	25.6 – 27.6 Vdc (wet), 26.4 – 28.4 Vdc (gel)
Maintenance voltage	25.6 – 27.6 Vdc (wet), 26.4 – 28.4 Vdc (gel)

Battery temperature compensation (requires optional temp sensor)	30 mV/°C
High battery temperature (requires external sense wires)	Optional, 50°C audible alarm, 55°C switch off
Battery voltage sense (requires external sense wires)	Optional, max. 1 Vdc compensation / wire
Ah counter (based on internal bus)	60 – 80% of State of Charge
Ah counter (with optional external shunt)	Required when charging, dis-charging batteries externally.
Short circuit protection	Electronic, at max. charge current, switch off < 1 sec.
Reverse polarity protection	none
Reverse polarity detection	Yes, destructive, no hazard

4.3 Battery module (discharge mode)

Connected batteries are discharged.

Battery Voltage output Range	18 – 32 Vdc
Battery output Current	Max. 250 A dc continuous; 470 A dc peak (5 sec)
Ripple current	< 20 %pp

5. Solar module

Converts connected solar power to the internal 400Vdc bus. 2 inputs with each a MPP tracker. At 50W the module is live. This way hick-up starting behavior is prevented.

Solar Voltage	150 - 600 Vdc, \pm 5%
MPP voltage	100 - 450Vdc
MPP efficiency	99.9% (EU method)
No. of inputs	2
No. of MPP trackers	2
Max. input	5,5 kW, 2 x 15A
Start-up power (@ 100Vdc)	50W
Efficiency (EU)	> 96% (EU method)
Galvanic Separation	Yes
Nighttime Tare Losses	< 2 W
Reverse polarity withstand current	15A/input
DC disconnection	Optional, 2 x 600V, 15A, double pole

6. Wind module

The specifications below are relevant to a specific Wind Turbine that is optimized with the PowerRouter. More information is available on request.

6.1 Generator*

Motor type	Direct drive, Permanent Magnet, 3 phase
No of poles	14
Stator resistance	1.41 Ω
Generator input Voltage	0 – 280 Vac, 3- phase (ph-ph)
Generator input Frequency (electric)	0 – 60 Hz
Generator input current	0 – 12 A
Power continues	3000W
Power peak	5000W

*No load voltage

6.2 Wind module (generator mode)

Cut-in frequency	> 15 Hz (el)
Cut out frequency low	$13.5 < f(\text{el}) < 21$
high	$50 < f(\text{el}) < 55$
Protection	
Generator break voltage	$248 < V_{\text{ac}} < 272^*$
Generator trip frequency	$54 < f(\text{el}) < 59^*$
Generator break current	1000 Apeak
Mast vibration	Signal by external CAN communication from vibration sensor
MPP	Custom made
Break Relays	Available
Ramp up frequency	Optional**
Ramp up voltage	Optional**
Sampling frequency	1kHz
Efficiency	> 96%
No load power consumption	< 18W
Stand by power consumption	< 2W
Communication Cable length	5 – 120 M

* For redundancy optional brake module is advised

** To be determined in implementation process

7. Display

4 rows of 20 segments	
4 LEDs	3 x Blue, 1 x red. For function, see separate document
4 keys	Up; down; enter/confirm; cancel / go back
On/off switch (non disconnecting)	3-way, On; off; reset
Information displayed	**TBD. See separate document

8. Mechanical / Enclosure

8.1 Connections

AC- input and output	Screw terminal blocks, marked L,N, GND. Min. 25A, 250Vac, suitable for 0.5 – 16 mm wires. Provided with a strain relief suitable for 10 -14 mm2 dia cables MC4 type connectors (2 x male, 2 x female)
Solar	
Wind	
Brake control	Screw terminal blocks, suitable for 0.2 – 2.5 mm2 wires. Provided with a combined strain relief suitable for 5 -10 mm dia cables.
Generator power line input	Screw terminal blocks, marked L1,L2,L3,GND. Suitable for 0.5 – 16 mm wires.
Battery	
Cables	Suitable for 35 – 95 mm2 cables. Colour red (+) and black (-)
Battery temperature sensor (optional)	Six poles screw terminal blocks, suitable for 0.2 – 2.5 mm2 wires, marked TMPS, gnd. Provided with a combined strain relief suitable for 5 -10 mm dia cables
External Shunt	RS-485 (RJ-45)*
Compensation leads	RS-232 (without level shifting) (RJ-45)*
Battery communication protocol	RS485 (shared RJ-45)* CAN (shared RJ-45) Ethernet (RJ-45)
Data connections	
Alarm relays NO/NC	Two screw terminal blocks, suitable for 0.2 – 2.5 mm2 wires, marked NO, NC. Provided with a combined strain relief suitable for 5 -10 mm dia cables

* Hardware provisions provided

8.2 Enclosure

No. of modules	1	2	3	4
Dimensions (W, H, T) (mm)	272 x 505 x 147	544 x 505 x 147	765 x 505 x 147	1036 x 505 x 147
weight (kg)	< 10	< 15	< 20	< 28
Degree of protection	IP 23 (indoor, dust free, rain protected)			
Grounding terminal	Min. M6 stud			
Fire enclosure	Per EN 60950-1			
External materials	Flame retardant, min. 5VB; decorative parts min. HB			
Internal materials	Min. V-2, exceptions per EN 60950-1			
Mounting	Landscape, wall mounted by separate mounting bracket. Max. 4 mounting points, only one type of commonly used screw or bolt			
Appearance	To be defined by customer drawing			
Handling	Openings or means for carrying. Can be put on the floor vertical without damaging connectors			
Connection compartment	Separate from electronics. Bottom cover needs to be replaced after installation. Secured by screws.			
Openings	In top, bottom, front and rear per EN60950. Opening of top part results in loss of warranty.			
Markings	See separate document.			

8.3 Packaging

Weight	< 25% of product weight			
No. of modules	1	2	3	4
Dimensions (W x H x T) (mm)	372 x 610 x 240	644 x 610 x 240	865 x 610 x 240	1136 x 610 x 240
Materials	100% recyclable			
Handling	Openings or handles for carrying			
Color	Per branding			
Markings	Nedap and/or OEM name, product name, type no., warnings, CE logo, date of manufacturing (serial nr.) barcode, transport directions			
Transport	upright			
No of layers stackable	3			

8.4 Environment & Certification

Operating Temperature Range (full power)	0 °C to 40 °C (derating at temperatures from 40 °C to 50 °C)
Storage Temperature	- 40°C to 70 °C
Humidity	Maximum 95%, non condensing
PCB humidity protection	Conformal coating
Noise at full load	TBD
Regulatory Approvals and Standards	CE
Safety	EN 60335-1, EN 60335-2-29, EN 60950-1, EN 62040-1, EN 62109-1, ETL-pending
Emission	EN 55014-1, -2, EN 61000-3-2, -3, EN 61000-6-2, -3
Immunity	EN 55014-2
Vibration and shock levels (incl. packaging)	MIL810G, Method 514.6, ISTA procedure 1H
Shock proof (incl. packaging)	EN 60068-2-27, UN-D 1400, Progr. 1: 7 drops from 55 cm.
MTBF	> 300.000 hours @ 50% P nom, UDC nominal @ 25°C
MTTF	10 years
FMEA	No unsafe situations allowed