



BENEFITS TO HELP YOU HARVEST MORE GREEN

Magnetek's PVI-CENTRAL-150/150-TL grid-tied systems are designed for large solar applications such as "big box" retail, office buildings, industrial facilities or ground mount installations. Harvest more green with Aurora's Maximum Power Point Tracking (MPPT) algorithm that maximizes energy produced under varying light conditions. The inverter's Insulated Gate Bi-polar Transistors (IGBTs) reduce thermal energy losses for optimum performance.

These commercial-grade inverters feature scalability in a common-enclosure package that is delivered pre-configured and pre-tested. In addition to reducing on-site installation wiring and testing, this industry-leading technology provides cost-effective solutions with smaller footprints and increased reliability.

Applications flexibility is further enhanced by the availability of models with and without isolation transformers that are self contained within the inverter rack.

The development of the PVI-150/150-TL was in response to the rapidly growing global demand for environmentally friendly power sources. Magnetek's inverters deliver a unique combination of efficiency, flexibility and redundancy to the renewable energy market, demonstrating our ongoing commitment to world-class energy solutions.

Maximize power harvest

- High conversion efficiency (CEC efficiency 96%) for maximum power harvest
- Wide operating voltage range of 330-600 Vdc increases energy collected
- Self-tuning MPPT power curve optimizes energy harvest
- Multiple input MPPT through modular design for array efficiency

Flexible configuration

- Independent modules are configurable in multi-master mode or master-slave mode, providing power redundancy
- Optional module grounding of (+) leg for application flexibility

Low installation and maintenance costs

- Module design offers unobstructed front access to modules and power boards for quick inverter installs and simplified maintenance
- Reduced wiring for ease of installation
- Hot-swappable module replacement simplifies maintenance

Extended performance

- A broad range of communications options: dial up, ISDN, Ethernet, DSL, GSM, and the optional FlyBy Communication System hardware/software, for instant access to system status
- Reduced sensitivity to a single fault; in case of a component fault, the system continues operating derated to 100kW
- Five-year warranty extendable to 20 years

HARVEST MORE GREEN™

BLOCK DIAGRAM 100kW – 150kW

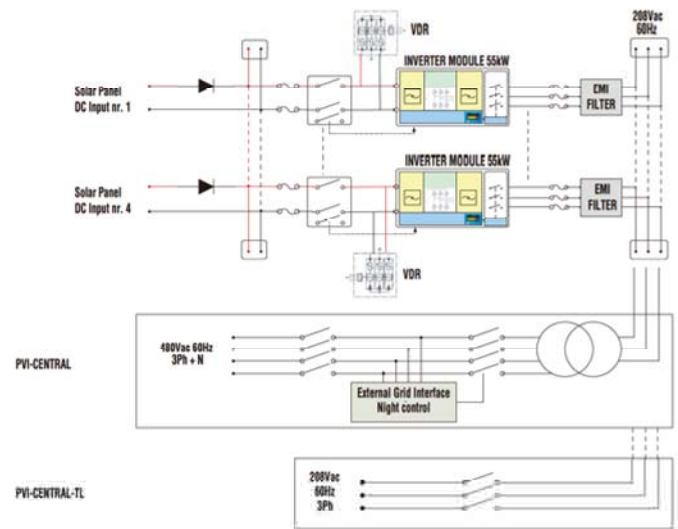

CHARACTERISTICS	PVI-CENTRAL-150 w/transfer	PVI-CENTRAL-150-TL w/o transformer
Input Parameters		
Maximum recommended PV power (kWp), Total (master slave mode) Per Channel (multi-master mode)	172.5 57.5	172.5 57.50
Absolute maximum input voltage (Vdc)	600	600
MPPT input voltage range Vdc	330-600(400 nominal)	330-600(400 nominal)
Maximum input current (Adc), Master-slave mode Multi-master mode (per module)	454 151	454 151
Input Reflected Ripple voltage	< 3%	< 3%
Number of DC inputs available (multi-master configuration)	2	2
Input overvoltage protections	2 (1 of each input)	2 (1 of each input)
Output Parameters		
Nominal AC Output Power (kW)	156	156
Nominal AC Output Current (Arms)		
208Vac Version	416	416
480Vac Version	180	N/A
AC Output Voltage range (Vrms)	3 x 200 +/-10% or 3x480 +/-10%	3 x 200 +/-10%
Nominal AC Frequency (Hz)	50 / 60	50 / 60
Power Factor	1 (@ Pac nominal)	1 (@ Pac nominal)
AC Current Harmonics (THD%)	< 3% (@ Pac nominal)	< 3% (@ Pac nominal)
Inverter Switching Frequency (kHz)	18	18
AC side overvoltage protection	Yes	Yes
Conversion Efficiency		
Peak Efficiency % (@ Vin nom)	96.3%	97.42%
CEC Efficiency % (@ Vin nom) 208	96%	96%
CEC Efficiency % (@ Vin nom) 480	96%	N/A
Environmental Parameters		
Environmental Protection Degree	NEMA 2/NEMA 3R	NEMA 2/NEMA 3R
Operating Temperature Range	-10°C...+50°C	-10°C...+50°C
Relative Humidity (non-condensing)	< 95%	< 95%
General Data		
Auxiliary Voltages Consumption (W)	<0.2% of PACnom	<0.2% of PACnom
Night time losses (W)	<30W	<30W
Local Communication	1x RS485 + 1x RS485 (dedicated to String combiner-Box)	1x RS485 + 1x RS485 (dedicated to String combiner-Box)
Remote Communication (optional)	Aurora Easy Control (Dial-Up, ISDN, Ethernet, DSL, GSM)	Aurora Easy Control (Dial-Up, ISDN, Ethernet, DSL, GSM)
User Interface	2-lines Display (on each inverter module)	2-lines Display (on each inverter module)
Mechanical Characteristics		
Dimensions (WxHxD) (mm) (*) Output Air conduit not included	1250 x 1570(*) x 810/49.2"x61.8"x31.8"	1250 x 1570(*) x 810/49.2"x61.8"x31.8"
Overall Weight (kg)	900/1980	480/1056
55kW module Weight (kg)	65/143	65/143
Required Ambient Air Cooling Flow	2000m³/h/3600CFM	2000m³/h/3600CFM
Approvals		
EMC	FCC part 15	FCC part 15
CE Compliance	Yes	Yes
Grid connection (pending)	DKS940 Ed. 2.2, VDEW, UL1741, RD1663/2000	DKS940 Ed. 2.2, VDEW, UL1741, RD1663/2000