



日煬國際事業股份有限公司
 JD Auspice Co., Ltd.

stringMoni[®]

2011 Catalogue



VIM-ANTI
 VIM-M
 VIM-O
 VIM-P
 VIM-1
 VIM-S
 VIM-S
 VIM-S



stringMoni®

Energy Management - Control solution for solar PV applications

- Modular local control system for PV plants
- Up to 16 DIN modules configuration equivalent to 280mm width
- stringMoni® Soft freeware software for easy product configuration
- stringMoni® can be formed by maximum 17 units
- stringMoni® can manage in addition to VIM-M master unit up to :
 - 1 VIM-P unit :
 - max 15VIM-S units :
 - max 7 VIM-O units :
 - max 1 VIM-1.

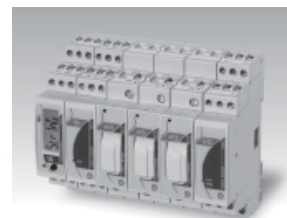

VIM-M, master module and data logger

- Master communication capability
- RS485 communication port (Modbus)
- Local communication bus management up to 15 mixed VIM-S, VIM-P and VIM-O units
- Two digital inputs
- Two temperature inputs : Pt100 or Pt1000
- Single virtual or real alarm set-point connectable to any available variable
- Data and event stamping system
- Display readout : 6 DGTs
- 12 to 28 VDC power supply
- Dimensions : 1-DIN module
- Protection degree (front) : IP40



Product Description

stringMoni® is a combination of modules which performs a complete control of a photovoltaic plant. The core unit is VIM-M which performs the local bus management of VIM-S, VIM-P both measuring units and VIM-O I/O unit. VIM-M assigns the proper local unit address automatically (up to 15 units) and gathers all the local measurements coming from VIM-S and VIM-P measuring units. VIM-M can provide by means of VIM-O modules two relay outputs so to manage alarms or/and external loads (like a lighting system, a module washing system and so on) and two temperature inputs. These latter two measuring inputs can become, according to the programmed function, also two digital inputs. Housing for DIN-rail mounting, IP40 (front) protection degree.

Type Selection

Function	4 :	Data storage 4Mbyte (*)
Power supply	A :	From 12 to 28VDC (*)
Communication	S1 :	RS485 Modbus (*)
Inputs	T2 :	two temperature inputs or two digital inputs for free of voltage reading contacts (*)
Option	X :	none

How to order

VIM-M 4 A S1 T2 X

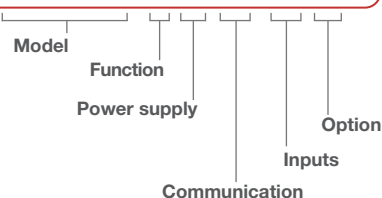

(*) as standard.



VIM-S, string measuring unit

- Direct DC voltage measurement up to 1000V
- Energy measurements : kWh
- Direct DC current measurement up to 16A or up to 30A without fuse
- Instantaneous variables data format : 4 DGTs
- Energies data format : 6 DGT
- Instantaneous variables : V, A, W.
- Accuracy : Class 1 (kWh) ± 0.5 RDG (current/voltage)
- Auxiliary power supply from VIM-M unit
- String alarm management by means of VIM-M unit only
- Fuse blow detection by means of VIM-M unit only
- PV module connection control by means of VIM-M unit only.
- Integrated 10.3x38mm fuse holder for string protection
- Dimensions : 1-DIN module
- Protection degree (front) : IP40

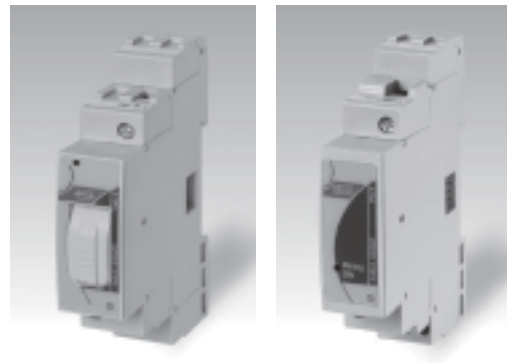

Product Description

Variables measuring unit with built-in protection fuse holder (the fuse is not provided); particularly indicated for DC current, voltage, power and energy metering in PV solar applications. The current inputs/outputs and also the voltage inputs are made so to simplify the string common connections. Direct connection up to 16A or 30A depending on the model. Moreover the unit is provided with an auxiliary serial communication bus. Alarms, fuse blow detection, PV module connection and serial communication are managed by means of VIM-M module. Housing for DIN-rail mounting, IP40 (front) protection degree.

How to order

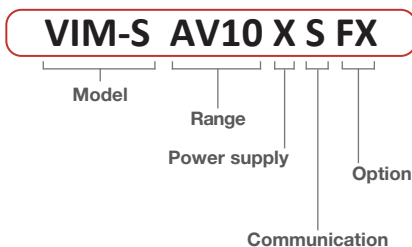

Type Selection

Range	AV10 :	1000V DC, 16A (Direct connection) (*)
	AV30 :	1000V DC, 30A (Direct connection) (**). In this case the "Option" is "XX".
Power supply	X :	from 12 to 28VDC, self-power supply from VIM-M unit
Communication	S :	auxiliary communication bus, compatible only to VIM-M module (*)
Option	XX :	none (no fuse holder)
	FX :	with fuse holder

(*) as standard.
(**) on request.



VIM-1, isolation enhancement unit



- Isolation enhancement of voltage measuring inputs to earth of VIM-S: from 800VDC (without VIM-1) to 1000VDC max.
- Dimensions: 1-DIN module
- Protection degree (front): IP40

Product Description

Isolation enhancement unit suitable to be used in combination with VIM modules. VIM-1 allows to enhance the isolation of the voltage measuring input to earth from 800Vdc to 1000Vdc. The module is to be mounted between the first VIM-S and all the other VIM modules. Housing for DIN-rail mounting, IP40 (front) protection degree.

How to order

VIM-1 1000

Standard model

Type Selection

Standard model

Isolation voltage 1000V:

isolation enhancement on VIM-S voltage measuring input to earth from 800VDC (without module) to 1000VDC.

Note: only one VIM-1 is needed per stringMoni®



VIM-P, environment variable unit

- Measurements : PV module temperature, air temperature, sun irradiation, wind speed
- Two temperature inputs : Pt100 or Pt1000
- One 120mV or 20mA DC input with scaling capability for irradiation measurement
- One pulse input for wind speed measurement
- Auxiliary communication bus to VIM-M unit
- Auxiliary power supply from VIM-M unit
- Dimensions : 1-DIN module
- Protection degree (front) : IP40

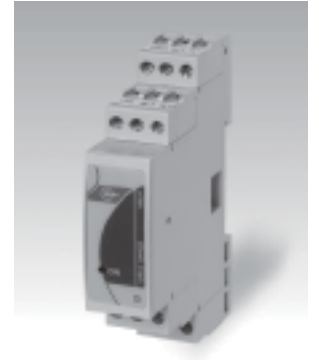

Product Description

Environment variable measurement unit particularly indicated for PV module temperature, air temperature, sun irradiation, wind speed metering in PV solar applications. Moreover the unit is provided with a specific serial communication bus which is managed by means of the additional VIM-M module. Housing for DIN-rail mounting, IP40 (front) protection degree.

Type Selection

Range	2TIW :	Two "Pt" temperature type probes, mV sun irradiation and wind speed measuring inputs (*)
	2TCW :	Two "Pt" temperature type probes, mA sun irradiation and wind speed measuring inputs (*)
Power supply	X :	from 12 to 28VDC, self-power supply from VIM-M unit
Communication	S :	auxiliary communication bus, compatible only to VIM-M module (*)
Option	Z :	none

(*) as standard.

How to order

VIM-P 2TIW X S X

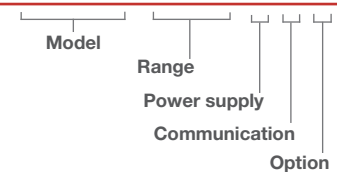



VIM-O, inputs/outputs unit

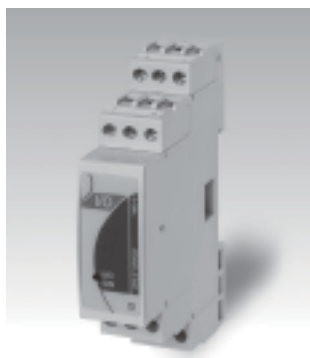

- Expansion I/O module (digital inputs and outputs)
- Two relay outputs managed by the VIM-M module
- Two digital inputs managed by the VIM-M module
- Auxiliary power supply from VIM-M module
- Dimensions : 1-DIN module
- Protection degree (front) : IP40

Product Description

I/O unit suitable to be used in combination with VIM-M modules. VIM-O allows to add, for every single unit, two digital inputs and two relay outputs to a VIM-M based system. Housing for DIN-rail mounting, IP40 (front) protection degree.

How to order

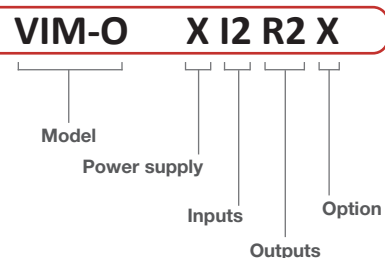

Type Selection (Standard model)

Power supply	X :	from 12 to 28VDC, self-power supply from VIM-M unit
Inputs	I2 :	two digital inputs (*)
Outputs	R2 :	two relay output (*)
Option	X :	none

Type Selection (Antitheft model)

Power supply	X :	from 12 to 28VDC, self-power supply from VIM-M unit
Inputs	I3 :	three digital inputs (*)
Outputs	R1 :	one relay output (*)
Option	AT :	antitheft compatibility

Note:

in case of "Antitheft application" every single stringMoni[®] can manage the combination of one VIM-O.X.I3.R1.AT module and up to three VIM-O.X.I2.R2.X modules.

(*) as standard.



VIM-ANTI, Antitheft sensor for VIM-O with “ANTI” option



- Plastic fibre optic sensor
- Sensing distance up to 200m
- Static output compatible with VIM-O “ANTI” option
- Auxiliary power supply from VIM-O “ANTI” option
- Dimensions: 14 x 31 x 73 mm housing
- Protection degree (front): IP50

Product Description

Antitheft plastic fibre optic sensor to be used in combination with VIM-O “ANTI” I/O unit, suitable to carry out an anti theft control on PV modules which are passed by 2.2 mm plastic fibre optic. The maximum loop distance which can be covered by the sensor is 200m. Housing for DIN-rail mounting, IP50 (front) protection degree.

How to order

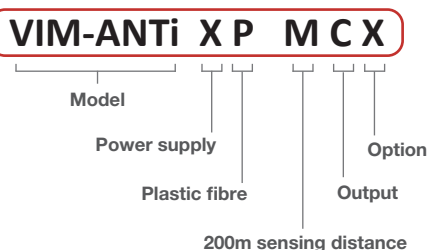

Type Selection

Power supply	X :	from 12 to 28VDC, self-power supply from VIM-O “ANTI” option unit	Sensing distance	M :	200m (*)
Fibre optic	FO :	plastic (*)	Output	C :	open collector
			Option	M :	none

(*) as standard.

Product Description

FO22-1000 is a specific plastic fibre optic cable which is made for VIM-ANTI sensor and is supplied in a quantity of 1000m. The working temperature is -55 to 70°C.

How to order

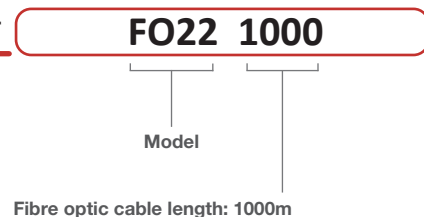



VIM-M Display and LED specification

Display		1 line (max: 6-DGT)
Type :		LCD, h 7mm
Information read-out :		From 4 to 6-DGT depending on the information.
LED		
Type :		Dual colour
Status and colour :		Green steady light : the module is power supplied and there is no communication on the RS485 bus. Green blinking light : the communication on the RS485 bus is working. Red : alarm detected (any). In case of alarm/communication condition the LED alternates its colour from red (alarm) to green. The blinking time is approx. 1 second.

VIM-S LED specification

LED		
Type :		Multicolor
Status :		ON steady light : the module is power supplied and there is no alarm.

Colour AV10 range code

Green: the power supply is ON, there is a string current up to 1A; Yellow: there is a string current from 1.1 to 3A; Light orange: there is a string current from 3.1 to 6A; Orange: there is a string current from 6.1 to 8A; Dark orange: there is a string current from 8.1 to 10A; Red: there is a string current higher than 10A; White: the unit is enabled by VIM-M module for data reading and displaying. Green ⇒ OFF: module not acknowledged in the StringMoni®. Cycling from blue to any other colour listed above (from yellow to red): string alarm. Cycling from blue to green: blown fuse. Cycling from blue to violet: inverted string polarity. Cycling from white to any other colour: the unit is enabled by VIM-M module for data reading and displaying and shows the status of the module according to the colour list above. The cycling time is approx. 1 second.

Colour AV30 range code

Green: the power supply is ON, there is a string current up to 1A; Yellow: there is a string current from 1.1 to 6A; Light orange: there is a string current from 6.1 to 12A; Orange: there is a string current from 12.1 to 16A; Dark orange: there is a string current from 16.1 to 20A; Red: there is a string current higher than 20A; White: the unit is enabled by VIM-M module for data reading and displaying. Green ⇒ OFF: module not acknowledged in the StringMoni®. Cycling from blue to any other colour listed above (from yellow to red): string alarm. Cycling from blue to violet: inverted string polarity. Cycling from white to any other colour: the unit is enabled by VIM-M module for data reading and displaying and shows the status of the module according to the colour list above. The cycling time is approx. 1 second.

VIM-P LED specification

LED		
Type :		Multicolor
Status and colour :		Green: the power supply is ON. White: the unit is enabled by VIM-M module for data reading and displaying.



VIM-O LED specification

LED

Type :	Multicolor
Status and colour :	Green : the power supply is ON. White : the unit is enabled by VIM-M module for data reading and displaying. Red : one or both digital inputs are activated. Blue : one or both digital outputs are activated. Cycling from one colour to any other one: the unit shows the status of the module according to the colour list above. The cycling time is approx. 1 second.

VIM-ANTi LED specification

LED

Power supply status :	Green : the power supply is ON
Loop status :	Red : the optical loop is closed

VIM-M input specifications

LED

Number of inputs :	2
Working mode :	First input : detection of ON/OFF status Second input: counting of pulses coming from an energy meter
Purpose :	First input : trip of protection detection, the status is transmitted only by means of the communication port. Second input : trip counter, interfacing with an energy meter (-kWh) so to measure the total efficiency of the system.
Input frequency :	20Hz max, duty cycle 50%
Pre-scaler adjustment :	From 0.001 to 10.000 kWh/pulse (only for the second input)
Contact measuring voltage :	3.3VDC
Contact measuring current :	<1mA
Contact resistance :	≤1kΩ closed contact ; ≥20kΩ open contact
Insulation :	See the table "Insulation between inputs and out-puts"

Temperature inputs

Number of inputs :	2
Temperature probe :	Pt100, Pt1000
Number of wires :	2 or 3-wire connection
Wire compensation :	Up to 10Ω.
Accuracy (Display + RS485) :	See "Temperature input characteristics"
Temperature drift :	±150ppm/°C
Engineering unit :	Selectable °C or °F
Insulation :	See the table "Insulation between inputs and out-puts"

Key-pad

1 push-button for variable scrolling and programming.
Full programming can be carried out only using stringMoni® Soft.

VIM-S input specifications

Rated inputs

Current type :	1 (shunt)
Current range :	AV10 range : 16ADC@40°C, 15A@50°C, 14A@55°C, 12A@60°C, 10A@65°C AV30 range : 30ADC@55°C, 25ADC@60°C, 20ADC@65°C
Voltage :	AV10 range : 1000Vdc , AV30 range : 1000Vdc

Accuracy

	(@25°C ±5°C, R.H. ≤60%)
AV10 range code	
Current	±(0.5%RDG+2 DGT) from 0.05A to 16A
Voltage	±(0.5%RDG+2 DGT) from 20V to 1000V
Power	±(1% RDG+ 2DGT)
Energy :	±(1% RDG)



VIM-S input specifications (cont.)

Rated inputs

Start up current	0.05A
Start up voltage	10V
AV30 range code	
Current	±(0.5%RDG+2 DGT) from 0.2A to 30A
Voltage	±(0.5%RDG+2 DGT) from 20V to 1000V
Power	±(1%RDG+2DGT)
Energy	±(1%RDG)
Start up current	0.2A
Start up voltage	10V

Temperature drift

Measurement sampling time	≤200ppm/°C
Variables format	2 sec.
Instantaneous variables	4-DGT (A, W), 5-DGT (V)
Resolution	0.1V; 0.01A; 0.01kW
Energies	Total:5+1 DGT (0.1kwh)

Max. and Min. data format

See "Stored set of variables coming from ..."

Input impedance

AV10 range code

Voltage	> 2.5MΩ
Current	< 0.006Ω(+ fuse impedance) @ 0.5 Nm(screw terminal torque). For current input of 16A the fuse has therefore a nominal current of 32A AC. The maximum dissipation power has not to exceed 2W

AV30 range code

Voltage	>2.5M
Current	< 0.003Ω@0.5 Nm (screw terminal torque).

Voltage Overloads

Continuous	1100V
For 500ms	1600V
To earth	800V(extended to 1000V in case of combined use of VIM-1.1000V unit)

Current Overloads

Continuous	AV10 range: 16A , AV30 range: 30A
For 1s	AV10 range: 100A max , AV30 range: 150A max

Protection

Fuse holder	Integrated into the module
Fuse type	gPV
Fuse size	10x38mm (IEC60269-1-6)
Fuse current	Fuse NOT provided.

Note :

the fuse rated current has to be ≥1.4 I_{sc} at 45°C ambient temperature. See fuse manufacturer specifications for further details including de-rating caused by higher ambient temperature.

VIM-P input specifications

Temperature drift

Variables format	≤200ppm/°C
Instantaneous variables	4 DGT (Temperature, solar irradiation and wind speed)
Resolution	0.1°C/0.1°F ; 1W/m ² , 1W/ft ² ; 0.1m/s, 0.1ft/s

Max. and Min. data format

See "Stored set of variables coming from ..."

Number of inputs

2 (Input 1 : PV module; Input 2 : air)

Temperature probe

Pt100 or Pt1000

Number of wires

Up to 3-wire connection

Wire compensation

Up to 10Ω.

Accuracy (Display + RS485)

See table "Temperature input characteristics"

Temperature drift

±150ppm/°C

Engineering unit

Selectable°C or °F

Insulation

See the table "Insulation between inputs and communication bus"

Irradiation sensor inputs

(range code: 2TIW)

Number of inputs	1
Range	0 to 120mVdc
Accuracy (@25°C ±5°C, R.H. ≤60%) (Display + RS485)	±(0.2%RDG+1DGT) 0% to 25% FS;
25% to 120% FS.	±(0.1%RDG+1DGT)
Temperature drift	±150ppm/°C
Scaling factor	
Operating mode	Dual scale : Input : programmable range from 0 to 999.9(mVDC) Display : programmable range from 0.000 to 9.999 (kW/m ² ,kW/ft ²)

Decimal point position

Fixed.
>30KΩ

Impedance

Overload

10VDC (measurement available up to 1V on both display and communication bus)

20Vdc

See the table "Insulation between inputs and communication bus"

For 1s

Insulation

Irradiation sensor input (range code: 2TCW)

Number of inputs	1
Range	0 to 20mADC
Accuracy (@25°C ±5°C, R.H. ≤60%) (Display + RS485)	±(0.2%RDG+1DGT) 0% to



VIM-P input specifications (cont.)

<p>Temperature drift Scaling factor Operating mode</p>	<p>25% FS;±(0.1%RDG+1DGT) 25% to 120% FS. ±150ppm/°C</p> <p>Dual scale : Input : programmable range from 0 to 25.0(mADC) Display Data format : programmable range from 0.000 to 9.999 (kW/m²,kW/ft²)</p>	<p>Wind speed sensor inputs Number of inputs Range Accuracy(@25°C ± 5°C, R.H. ≤60%) (Display + RS485) Temperature drift Scaling factor Operating mode</p>	<p>1 0 to 1000Hz max, duty cycle 50% ±(0.02%RDG+1DGT) 0% to 25% FS ±(0.01%RDG+1DGT) 25% to 110% FS. ±150ppm/°C</p> <p>Dual scale : Input : programmable range from 0 to 999.9 (Hz) Display : programmable range from 0 to 299.9 (m/s,ft/s)</p>
<p>Decimal point - position Impedance Overload Continuous</p>	<p>Fixed ≤22W 50mADC (measurement available up to 25mA on both display and communication bus)</p>	<p>Decimal point position Impedance Operating input Impedance Overload Continuous</p>	<p>Fixed and depending on the input /display scale. 680Ω 2.5V_{peak} to 9V_{peak}/ 5mA_{peak} to 35mA_{peak}, duty cycle 50% 220Ω</p>
<p>For 1s Insulation</p>	<p>150mADC See the table “Insulation between inputs and communication bus”</p>	<p>For 1s Insulation</p>	<p>7V_{RMS} / 25mA_{RMS} (AC/DC) 14V_{RMS} / 50mA_{RMS} (AC/DC) See the table “Insulation between inputs and communication bus”</p>

VIM-M Output specifications

RS485

<p>Type Connections Addresses Protocol Data (bidirectional)</p>	<p>Multidrop, bidirectional (static and dynamic variables) 2-wire. Max. distance 1000m 247, selectable by means of the front push-button MODBUS /JBUS (RTU) All variables, see table“Measured variables, data format and messages” in the VIM-S document</p>
<p>Dynamic (reading only) Static (writing only) Data format1 Baud-rate Driver input capability Special functions Insulation</p>	<p>All the configuration parameters. 1 start bit, 8 data bit, no parity,1 stop bit Selectable : 9600, 19200, 38400, 115200 bits/s Parity : none 1/5 unit load. Maximum 160 transceivers on the same bus. None See the table “Insulation between inputs and out puts”</p>

Auxiliary communication bus

This is the communication bus to the VIM-S, VIM-P and VIM-O units where VIM-M performs the master function in this network.VIM-M unit can gather the following information from the bus : All variables available on the bus ; Blown protection fuse ; PV reverse voltage and current polarity.The local address in both the VIM-S, VIM-P and VIM-O units is automatically assigned by VIM-M master unit based on their positions. It can manage up to 15 different addresses (units).

Insulation	See the table “Insulation between inputs and out-puts”
-------------------	--------------------------------------------------------



VIM-O Input/Output specifications

Maximum number of modules managed by every single

VIM-M module Up to 7

Digital inputs

Number of inputs	2
Working mode	Detection of OPEN/CLOSED contact status
Purpose	Trip of protection detection, the status is transmitted only by means of the communication port.
Input frequency	2Hz max, duty cycle 50%
Contact reading voltage	3.3VDC
Contact reading current	< 2mA
Contact resistance	≤ 300Ω closed contact ; ≥ 10kΩ open contact
Insulation	See the table “Insulation between inputs and out-puts”

Digital output

Number of outputs	2
Purpose	Alarm notification as a String alarm or as a digital input status changing (OR function); activation of a lighting system (by means of the internal clock or as a remote control); activation of a module washing system (by means of the internal clock, as a remote control or as a changing of efficiency of the PV panels).
Type	Relay, SPST type AC 1-5A @ 250VAC, AC 15-1A @ 250VAC, Available by means of VIM-O module only
Insulation	See the table “Insulation between inputs and out-puts”

VIM-M and VIM-P Temperature input characteristics

Probe	Range	Accuracy	Min Indication	Max Indication
Pt100	-50°C to +200.0°C	±(0.5%RDG +5DGT)	-50.0	+200.0
Pt100	-58°F to +392°F	±(0.5%RDG +5DGT)	-58.0	+392.0
Pt1000	-50°C to +200.0°C	±(0.5%RDG +5DGT)	-50.0	+200.0
Pt1000	-58°F to +392°F	±(0.5%RDG +5DGT)	-58.0	+392.0

VIM-O with “ANTi” option, Input/Output specifications

Maximum number of module managed by every single

VIM-M module Up to 1

Digital inputs

Number of inputs	3
Working mode	Detection of ON/OFF status
Purpose	Detection of the output status of up to 3 VIM-ANTI units, the same inputs can be used also to detect standard free of voltage contacts of other devices.
Working logic	The inputs in case of Antitheft purpose selection work as an OR logic (stringMoni® Soft), if this function is not enabled every input works independently from each other.
Input frequency	2Hz max, duty cycle 50%
Contact reading voltage	3.3 Vdc
Contact reading current	< 2mA
Contact resistance	≤ 300Ω closed contact ; ≥ 10kΩ open contact
Insulation	See the table “Insulation between inputs and out-puts”

Digital output

Number of outputs	1
Purpose	Antitheft notification in case of function enabling (stringMoni® Soft) or alarm notification as a String alarm or as a digital input status changing (OR function) ; activation of a lighting system (by means of the internal clock or as a remote control) ; activation of a module washing system (by means of the internal clock, as a remote control or as a changing of efficiency of the PV modules).
Type	Relay, SPST type AC1-5A@ 250VAC, AC15-1A@250VAC
Insulation	See the table “Insulation between inputs and out puts”



VIM-ANTi Antitheft sensor specifications

Maximum number of sensors managed by every single VIM-O “AT” module		Up to 3
Optical sensing		
	Maximum operational distance	200m (loop)
	Sensitivity	Automatic adjusted
	Light source	GaAIAs, LED 660 nm
	Light type	Red modulated
	Operating frequency	1 Khz
	Response time on fibre breaking	0.5 seconds
Fibre Optic		
	Material	Plastic
	Diameter	2.2mm
	Compatible model	PGU-CD1001-22
	Working temperature	-55 to + 70°C
Digital output		
	Number of outputs	1
	Type	Open collector
	Insulation	Operational insulation only (50VACRMS)
Power Supply		
	Connection	12 to 28 Vdc
	Cable	Lenhth : 0.5m, black colour, PVC material

Main Function

Displaying		
	Own VIM-M module	1 parameter per page See “Stored set of vari-ables from ...” and “Alarm and diagnostics messages”
	When a VIM-S module is selected	All the information related to the status of the string being selected by means of the front key (see “Variable” in the table “List of the variables that can be...”).
	When a VIM-P module is selected	All the information related to the status of the environment probes being selected by means of the front key (see “Variable” in the table “List of the variables that can be...”).
	When a VIM-O module is selected	All the information related to the status of the inputs/outputs being selected by means of the front key (see “Variable” in the table “List of the variables that can be...”).
Password		Numeric code of max. 4 digits; 2 protection levels of the programming data:
	1st level	Password"0", no protection;
	2nd level	Password from 1 to 9999, all data are protected
Reset		By means of the front push-button when the relevant VIM-S is selected
Alarms		
	Number of alarms	One, independent for every single available variable (see the table “List of the variables that can be...”)
	Alarm types	Virtual alarm or real alarm
	Alarm modes	Up alarm, down alarm (see the table “List of the variables that can be connected to ...”)
	Set-point adjustment	From 0 to 100% of the display scale
	Hysteresis	From 0 to full scale
	On-time delay	0 to 3600s
	Output status	Selectable; normally deenergized or normally energized
	Min. response time	≤ 700ms, set-point on time delay: “0 s”



Main Function (Cont.)

Clock

Functions
Daylight-saving enabling
Time format
Date format

Universal clock and calendar.
 Activation : NO/YES
 Hour : minutes with selectable 24 hours or AM/PM
 Month-Day, where the month is displayed in a three letter format (e.g. : JAN-FEB-MAR) and the date as a number.
 Year is displayed in a two digit format

Battery life

10 years

Data logging

Data

The data are not available on the display but they can be both checked and downloaded using RS485 communication port in combination with stringMoni[®] Soft software.

Function enabling
Function description

Activation: NO/YES
 All the events gathered from both VIM-S, VIM-O and VIM-P modules are stored individually into the internal memory.

Stored data type

Variables : V, A, W, Wh, PV module temperature, ambient temperature, irradiation, wind speed, string efficiency and BOS efficiency.

Storage interval
Sampling management

Storage intervalSelectable : 1-5-10-15-30-60 minutes
 The sample stored within the selected time interval results from the continuous average calculation of the measured values. The average is calculated with an interval within two following measurements of aPPRox. 2s.

Storage duration

Before overwriting:depending on the storage interval, see "Historical data storing time table"

Data format
Storage method
Memory type
Memory retention time

Variables, date (dd:mm:yy) and time (hh:mm:ss)
 Circular FIFO
 Flash
 10 years

Event logging

Data displaying

The data are not available on the display but they can be both checked and downloaded using RS485 communication port in combination with stringMoni[®] Soft software.

Function enabling
Type of stored events

Activation : NO/YES
 VIM-O digital input/output status change (real and virtual alarms), string alarms (see "String control"), VIM-M 1st digital input status change. The events are recorded as soon as they occur. For more information about the type and stored data, see "List of the variables that can be connected to"

Number of events

Max. 10 000.

Data reset
Data format
Storage method
Memory type
Memory retention time

The reset can be carried out only using stringMoni[®] Soft.
 Event, date (dd:mm:yy) and time (hh:mm:ss)
 Circular FIFO
 Flash
 10 years

String control

Function enabling
Function selection
Function description

Activation : NO/YES
 Match max. control or median control
 Match max. control : this function is helpful only if there are at least two string controls (VIM-S units). The highest value of the measured string power among those available is used as a reference value. The alarm set-point is a value which can be set by the user as a percentage of the reference value below which there is the alarm condition.
 Median control : the measurement of the string power is performed by the local VIM-S module individually. Within the VIM-M system all values coming at the same instant from



Main Function (Cont.)

String window alarm

every VIM-S module are used to calculate the “median” value which becomes the reference value to which the dynamic window set-point (in percentage set by the user) is linked. The abnormal condition is detected when the measured instantaneous string power is out of the set window alarm. The alarm activates, with reference to the failed string, either a relay output (only in case of “VIM-O” connection) or/and a message which is transmitted by means of the RS485 communication port to an acquisition system. The alarm is set as the string power control, the value is programmable in percentage (of the measured string value) from 0.1 to 199.9.

Other alarms

The alarms can be connected also to: A and V

“PV string” efficiency measurement

Function enabling Control type “0”

Activation : NO/YES Three type of controls are available
The VIM-P unit is not available therefore the single strings are used to calculate the reference value for the efficiency calculation. The VIM-P module is present and both PV module temperature and irradiation are measured to calculate the reference value for the efficiency calculation.

Control type “1”

The VIM-P module is present and both ambient temperature and irradiation are measured to calculate the reference value for the efficiency calculation.

Control type “2”

BOS efficiency measurement

The total efficiency measurement is based on the comparison between the generated energy and the exported energy supplied to the grid. The grid supplied energy is measured by means of a “SO” output coming from an energy meter like EM21-72, EM24-DIN, EM26-96 where the pulsating output (-kWh) is connected to the second digital input of VIM-M.

Fuse blow detection

(only AV10 range code)

Warning message transmission through the local port to the VIM-M unit.

Wrong PV string connection

Warning message transmission through the local port to the VIM-M unit.

Note:

the “String control”, the “PV string efficiency” and the “BOS efficiency” can be carried out only in case a minimum system is available like a VIM-M, plus a VIM-S, plus a VIM-P and an energy meter with pulsating output.



Insulation between inputs and outputs

Module	Type of input/output	Any	VIM-M			VIM-P			VIM-O		VIM-S		
		Local bus	DC Power supply	Temperature or digital inputs : Ch1, Ch2	RS485	Temperature : Ch1, Ch2	Solar irradiation	Wind speed	Digital inputs : Ch1, Ch2, Ch3	Relay outputs : Ch1, Ch2	Input string (V-)	Input string (A+)	Output string (A+)
Any	Local bus	-	0kV	0kV	0kV	0kV	0kV	0kV	4kV	4kV	4kV	4kV	4kV
VIM-M	DC Power supply	0kV	-	0kV	0kV	0kV	0kV	0kV	4kV	4kV	4kV	4kV	4kV
	Temperature or digital inputs : Ch1, Ch2	0kV	0kV	-	0kV	0kV	0kV	0kV	4kV	4kV	4kV	4kV	4kV
	RS485	0kV	0kV	0kV	-	0kV	0kV	0kV	4kV	4kV	4kV	4kV	4kV
VIM-P	Temperature : Ch1, Ch2	0kV	0kV	0kV	0kV	-	0kV	0kV	4kV	4kV	4kV	4kV	4kV
	Solar irradiation	0kV	0kV	0kV	0kV	0kV	-	0kV	4kV	4kV	4kV	4kV	4kV
	Wind speed	0kV	0kV	0kV	0kV	0kV	0kV	-	4kV	4kV	4kV	4kV	4kV
VIM-O	Digital inputs : Ch1, Ch2, Ch3	0kV	0kV	0kV	0kV	0kV	0kV	0kV	-	4kV	4kV	4kV	4kV
	Relay outputs : Ch1, Ch2	4kV	4kV	4kV	4kV	4kV	4kV	4kV	4kV	-	4kV	4kV	4kV
VIM-S	Input string (V-)	4kV	4kV	4kV	4kV	4kV	4kV	4kV	4kV	4kV	-	4kV	>5MΩ
	Input string (A+)	4kV	4kV	4kV	4kV	4kV	4kV	4kV	4kV	4kV	4kV	-	4kV
	Output string (A+)	4kV	4kV	4kV	4kV	4kV	4kV	4kV	4kV	4kV	>5MΩ	4kV	-

Note: The isolation between the two relay outputs is 4kV.

0kV	Inputs / outputs are not insulated. Use insulated probes and free of voltage contacts inputs.
4kVrms	EN61010-1, IEC60664-1 - Over-voltage category III, Pollu. on degree 2, double insulation on systems with max. 300Vrms to ground
4kVrms	IEC60664-1 - Using protection device with clamping voltage ≤ 4kV (surge suppressor) the system insulation can be considered as reinforced for string output voltage up to 1000V (800V to earth). IEC60664-1, IEC61730-2 application class B : impulse withstand voltage 1,2/50
4kV	Only if the fuse is not present. The fuse is only for over-current protection (it has not to be considered as a disconnecting device).

General specifications

Operating temperature
Storage temperature
Over voltage category

See table "String current vs. operating temperature".
-30 to +70°C (-22°F to 158°F) (R.H. < 90% non condensing @ 40°C)
Cat. III (IEC 60664, EN60664)

Insulation (for 1 minute)
Dielectric strength
Noise rejection

For inputs from string : equivalent to Cat. I, reinforced insulation.
See table "Insulation between inputs and out-puts"
4000 VAC RMS for 1 minute

EMC (Immunity)

CMRR

65 dB, 45 to 65 Hz
According to EN61000-6-2
EN61000-4-2 : 8kV air dis-charge, 4kV contact;

Electrostatic discharges
Immunity to irradiated
Electromagnetic fields
Immunity to Burst
Immunity to conducted
disturbances
Surge

EN61000-4-3 : 10V/m from 80 to 3000MHz;
EN61000-4-4 : 4kV on power lines, 2kV on single lines;

EMC (Emission)

Radio frequency suppression

EN61000-4-6 : 10V from 150KHz to 80MHz;
EN61000-4-5 : 500V on power supply; 4kV on string inputs.
According to EN61000-6-3
According to CISPR 22



General specifications (cont.)

Standard compliance		IEC60664, IEC61010-1, EN60664, EN61010-1
Approvals	Safety	CE, cULus Listed
Housing	Dimensions (WxHxD) Material	17.5 x 90 x 67 mm Noryl, self-extinguishing : UL 94 V-0
Mounting		DIN-rail
Protection degree	Front Screw terminals	IP40 IP20

Connections

VIM-M		Screw terminal purposes 16 mm²	1+1 screw terminals : 1 positive for string input and 1 positive for string output (to the Inverter)
Connections	Screw-type		3 screw terminals : for negative connection of string
Cable cross-section area	1.5 mm ² max, Min./Max.screws tightening torque : 0.4 Nm / 0.8 Nm		
Screw terminal purposes 1.5 mm²	3+3 screw terminals used for two temperature inputs 3 screw terminals used for RS485 communication 2 screw terminals used for power supply	1.5 mm²	
VIM-S AV10		VIM-P	
Connections	Screw-type	Connections	Screw-type
Cable cross-section area	Min. 2.5 mm ² , max 6 mm ² in case of flexible wire, Max. 10 mm ² in case of rigid wire. Min./Max. screws tightening torque : 0.5 Nm / 1.1 Nm	Cable cross-section area	1.5 mm ² max. Min./Max. screws tightening torque : 0.4 Nm / 0.8 Nm
Current (+)	Max 1.5 mm ² , Min./Max. screws tightening torque: 0.4 Nm / 0.8 Nm	Screw terminal purposes 1.5 mm²	3+3 screw terminals used for two temperature probes 2 screw terminals used for wind speed sensor. 2 screw terminals used for solar irradiation sensor
Voltage (-)		VIM-O	
Screw terminal purposes 10 mm²	1+1 screw terminals : 1 positive for string input and 1 positive for string output (to the Inverter)	Connections	Screw-type
1.5 mm²	3 screw terminals : for negative connection of string	Cable cross-section area Relay outputs and digital inputs	Max. 2.5 mm ² Min./Max. screws tightening torque : 0.4 Nm / 0.8 Nm
VIM-S AV30		"X" type Screw terminal purposes 1.5 mm²	2+2 screw terminals : two for 1st relay output and two for 2nd relay output (SPST type)
Connections	Screw-type		2+2 screw terminals : two for 1st digital input and two for 2nd digital input
Cable cross-section area	Min. 2.5 mm ² , max 10 mm ² in case of flexible wire, Max. 16 mm ² , max 10 mm ² in case of rigid wire. Min./Max. Hole dimension : 7.2x5.1mm, screws tightening torque : 0.5 Nm / 1.1 Nm	"ANTI" type Screw terminal purposes 1.5 mm²	2 screw terminals for relay output (SPST type) 2+2+2 screw terminals : two for 1 st digital input, two for 2 nd digital input and two for 3 rd digital input
Current (+)	Max 1.5 mm ² , Min./Max. screws tightening torque : 0.4 Nm / 0.8 Nm	Weight (all modules)	Approx. 100 g (packing included)
Voltage (-)			

Power supply specifications

VIM-M		VIM-S-P-O	
Power supply	12 to 28 VDC	Power supply	Self-power supplied through the communication bus
Power consumption	≤ 1W	Power consumption	≤ 0.7W



String current vs. operating temperature

VIM-S AV10 Input current	VIM-O Max. contact current	Other modules	Operating temperature	
10A DC max.	2.5A	VIM-M, VIM-P	-25 to + 65°C	-13°F to 149°F
12A DC max.	3.0A	VIM-M, VIM-P	-25 to + 60°C	-13°F to 140°F
14A DC max.	3.5A	VIM-M, VIM-P	-25 to + 55°C	-13°F to 131°F
15A DC max.	4.0A	VIM-M, VIM-P	-25 to + 50°C	-13°F to 122°F
16A DC max.	5.0A	VIM-M, VIM-P	-25 to + 40°C	-13°F to 104°F
VIM-S AV30 Input current				
20A DC max.	2.5A	VIM-M, VIM-P	-25 to + 65°C	-13°F to 149°F
25A DC max.	3.0A	VIM-M, VIM-P	-25 to + 60°C	-13°F to 140°F
30A DC max.	3.5A	VIM-M, VIM-P	-25 to + 55°C	-13°F to 131°F

R.H. < 90% non condensing @ 40°C (104°F)

Sizing of JD Auspice DC power supply without antitheft functionality

VIM-S units	VIM-O units	VIM-P units	Consumption	Power supply part number
From 1 to 3	None	None	PS _w : 2.5W _{max}	PSU 24 05 1B or SPM1 24 1
From 1 to 3	1	1	PS _w : 5W _{max}	PSU 24 10 1B or SPM1 24 1
From 4 to 10	From 2 to 4	1	PS _w : 10,6W _{max}	PSU 24 18 1B or SPM3 24 1
From 11 to 14	1	1	PS _w : 9,8W _{max}	PSU 24 18 1B or SPM3 24 1
Max. 14	Max. 7	Max. 1		Note : VIM-P as 1.8W includes also the wind sensor consumption.

Note : the consumption above includes already one VIM-M unit without any antitheft management. For different units combination not mentioned above the consumption calculation is the following : $PSW < 1W + n_{VIM-S} * 0.5W + n_{VIM-O} * 0.7W + n_{VIM-P} * 1.8W$.
Where "n" is number of power supplied units.

Sizing of JD Auspice DC power supply with antitheft functionality

VIM-S units	VIM-O.X units	VIM-O.AT units	VIM-ANTI units	VIM-P units	Consumption	Power supply part number
10 to 14	None	1	3	None	PS _w : 12W _{max}	PSU 24 18 1B or SPM3 24 1
10 to 13	1	1	3	Up to 1	PS _w : 12,5W _{max}	PSU 24 18 1B or SPM3 24 1
10 to 12	2	1	3	1	PS _w : 14,2W _{max}	PSU 24 18 1B or SPM3 24 1
10	3	1	3	1	PS _w : 13,9W _{max}	PSU 24 18 1B or SPM3 24 1
Max. 14	Max. 3	Max. 1	Max. 3	Max. 1		Note : VIM-P as 1.8W includes also the wind sensor consumption.

Note : in order to carry out, in the stringMoni®, the proper antitheft functionality, one VIM-O.X.I3.R1.AT unit and up to three VIM-AT.X.P,M,C,X sensors have to be added, in this case the maximum equivalent added consumed power is 4W.

For different units combination not mentioned above the consumption calculation is the following :

$PSW < 1W + n_{VIM-S} * 0.5W + n_{VIM-O.X} * 0.7W + n_{VIM-O.AT} * 0.7W + n_{VIM-ANTI} * 1.1 + n_{VIM-P} * 1.8W$.

Where "n" is number of power supplied units.

Stored set of variables in the VIM-M module

No.	Variable	Data format	Notes
1	Temperature 1	-60.0 to 400.0	The range is extended so to cover both °C and °F indication
2	Temperature 2	-60.0 to 400.0	The range is extended so to cover both °C and °F indication
3	BOS efficiency	0.0 to 999.9	"Total efficiency" result in percentage
4	AC energy value	0.0 to 99999.9	The value is in kWh and is the result of the totalized pulses coming from external energy meter



Stored set of variables coming from every single VIM-S module

No.	Variable	Data format	Sub-address	Notes
1	V	0.0 to 1250.0	From 1 to 15	
2	A	0.0 to 20.00	From 1 to 15	
3	kW	0.0 to 99.99	From 1 to 15	
4	kWh	0.0 to 99999.9	From 1 to 15	
5	String efficiency	0.0 to 999.9		“PV string” efficiency result in percentage. Every string in the network has its own data.

Stored set of variables coming from every single VIM-P module

No.	Variable	Data format	Sub-address	Notes
1	Temperature 1 (PV module)	-60.0 to 400.0	From 1 to 15	PV module temperature (°C/°F). The range is extended so to cover both °C and °F indication
2	Temperature 2 (Environment)	-60.0 to 400.0	From 1 to 15	Ambient temperature (°C/°F). The range is extended so to cover both °C and °F indication
3	Solar irradiation	0.0 to 9.999	From 1 to 15	Irradiation kW/m ² (kW/feet ²). (e.g. in: 0 to 1kW/m ² (1kW/feet ²), out: 0 to 100mV)
4	Wind speed	0.0 to 299.9	From 1 to 15	Wind speed (m/s) or feet/s

Alarm and diagnostics messages

No.	Message	Notes
1	Conn.CY (AV10 only)	Fuse blow detection. The status of each fuse is indicated by the colour change of the relevant LED on the VIM-S module.
2	StrinG	String failure warning : the “String control” function has detected a failure. The STRING information is given in combination with the LED alarm on VIM-M and the LED colour code on every single string.
3	Conn.PY	The string is wrongly connected (reverse polarity)
4	SYStEM	Power-up self-test error
5	buS	Auxiliary bus communication error
6	ALArM	Variables alarm (any)
7	tHEft	Theft warning : removal of the PV modules in the fibre optic loop controlled by the relevant VIM-ANTi sensor. The THEFT information is given in combination with the LED alarm on VIM-M and the LED colour code on the relevant VIM-O.AT module.

Historical data storing time table

Time interval (minutes) (1)	From 1 to 15 strings			
	Data storing time			
	Min. days	Min. weeks	Min. months	Note
1	6	0	0	(2), (3), (4)
5	34	4	1	(2), (3), (4)
10	69	9	2	(2), (3), (4)
15	104	14	3	(2), (3), (4)
30	208	29	7	(2), (3), (4)
60	416	59	14	(2), (3), (4)

- (1) Every value stored in the memory, is the result of the average calcula. on, in the selected time interval of the variable being measured and sampled every 2 seconds.
- (2) A maximum of 10 000 variable sets can be stored into the memory independently from the type and quantity of managed modules (for a maximum of 15).
- (3) The stored variables are coming from the VIM-P module and are : PV module temperature, ambient temperature, irradiation and wind speed.
- (4) The stored variables are relevant to both String efficiency and BOS efficiency.



List of the variables that can be displayed and connected to ...

- RS485 communication port
- Real and virtual alarms and events
- Data-logging

No	Variable	Event logging	Data logging	Alarm output	Module (from)	Notes
1	°C (°F) (input 1)	Yes	Yes	Yes	VIM-M	As alternative of status detection (4)
2	°C (°F) (input 2)	Yes	Yes	Yes	VIM-M	As alternative of variable (5)
3	%BOS efficiency	Yes	Yes	Yes	VIM-M	BOS efficiency calculation of the PV plant (in case of one VIM-M unit only). In all other cases the calculation is made by the software.
4	ON / OFF status (input 1)	Yes	Yes	No	VIM-M	As alternative of variable (1)
5	kWh (input 2)	Yes	Yes	No	VIM-M	Counting of pulses coming from an energy meter, as alternative of variable (2)
6	Reset kWh (input 2)	No	No	No	VIM-M	Resetting of totalized pulses from AC energy meter
7	Error : 1	Yes	No	Yes (a)	VIM-M	Local bus communication problems
8	Error : 2	Yes	No	Yes (a)	VIM-M	Changed system modules configuration
9	Error : 3	Yes	No	Yes (a)	VIM-M	Incoherent programming parameters
10	Error : 4	Yes	No	Yes (a)	VIM-M	More than one VIM-P unit connected to the bus
11	Error : 5	Yes	No	Yes (b)	VIM-M	Short circuit on probe input 1
12	Error : 6	Yes	No	Yes (b)	VIM-M	Open circuit on probe input 1
13	Error : 7	Yes	No	Yes (b)	VIM-M	Short circuit on probe input 2
14	Error : 8	Yes	No	Yes (b)	VIM-M	Open circuit on probe input 2
15	Status : 1	Yes	No	No	VIM-M	Local programming access
16	Status : 2	Yes	No	No	VIM-M	Power ON / OFF
17	V	Yes	Yes	Yes	VIM-S	Available from every string
18	A	Yes	Yes	Yes	VIM-S	Available from every string
19	kW	Yes	Yes	Yes	VIM-S	Available from every string
20	kWh	Yes	Yes	No	VIM-S	Available from every string
21	Reset string kWh	No	No	No	VIM-S	Resetting DC string energy meter
22	Reset all strings kWh	No	No	No	VIM-S	Resetting all DC string energy meters
23	%string efficiency	Yes	Yes	Yes	VIM-S	String efficiency
24	Status: 1	Yes	No	Yes	VIM-S	Incoherent programming parameters
25	Status: 2	Yes	No	Yes	VIM-S	Fuse blow detection
26	Status: 3	Yes	No	Yes	VIM-S	Reverse string current or voltage
27	Status: 4	Yes	No	Yes	VIM-S	High temperature inside VIM-S unit
28	String control	Yes	Yes	Yes	VIM-S	
29	°C (°F) input 1	Yes	Yes	Yes	VIM-P	PV module temperature
30	°C (°F) input 2	Yes	Yes	Yes	VIM-P	Air temperature
31	kWp/m ² (kWp/ft ²)	Yes	Yes	Yes	VIM-P	Solar irradiation
32	m/s (ft/s)	Yes	Yes	Yes	VIM-P	Wind speed
33	Error : 1	Yes	No	Yes	VIM-P	Incoherent programming parameters
34	Error : 2	Yes	No	Yes (c)	VIM-P	Short circuit on probe input 1
35	Error : 3	Yes	No	Yes (c)	VIM-P	Open circuit on probe input 1
36	Error : 4	Yes	No	Yes (c)	VIM-P	Short circuit on probe input 2
37	Error : 5	Yes	No	Yes (c)	VIM-P	Open circuit on probe input 2
38	Status : input 1	Yes	No	No	VIM-O	ON /OFF status detection
39	Status : input 2	Yes	No	No	VIM-O	ON /OFF status detection
40	Status : output 1	Yes	No	No	VIM-O	ON /OFF status detection
41	Status : output 2	Yes	No	No	VIM-O	ON /OFF status detection
42	Error : 1	Yes	No	Yes	VIM-O	Incoherent programming parameters

Note about "Alarm output" : YES (a), YES (b) and YES (c) are according to the relevant letter "OR" logic alarms.

VIM-M connections

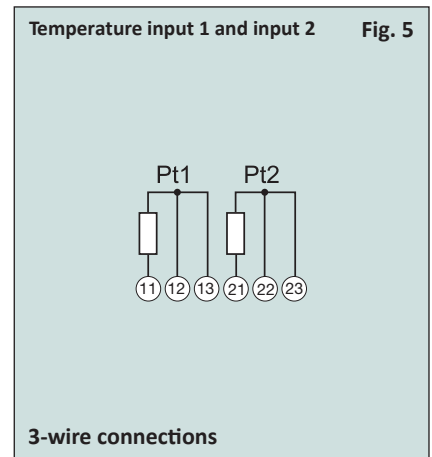
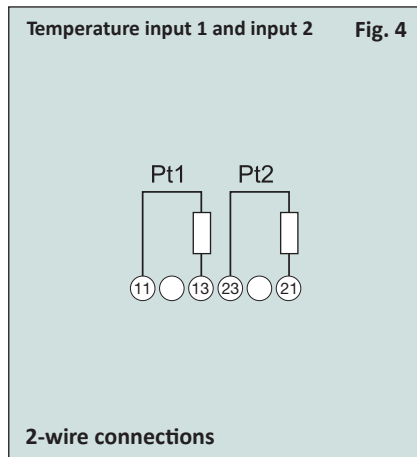
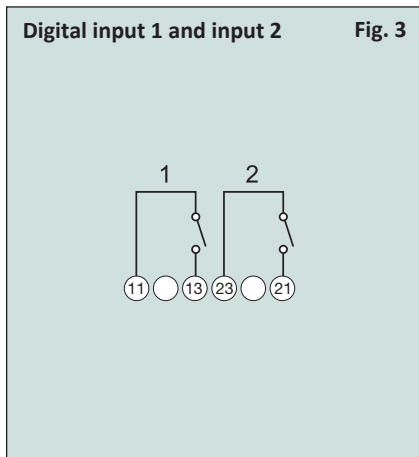
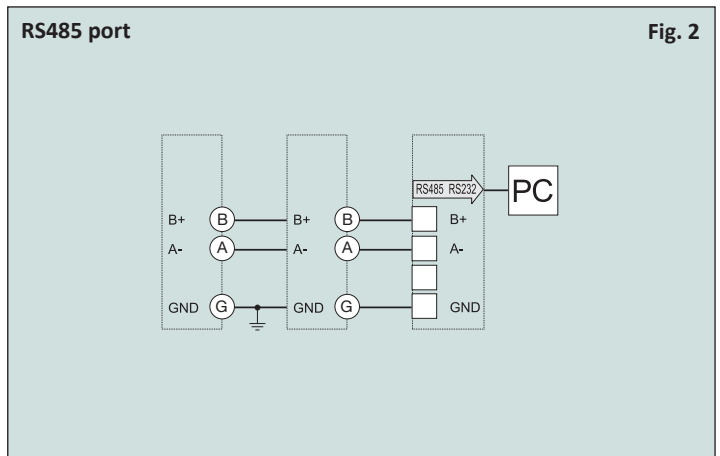
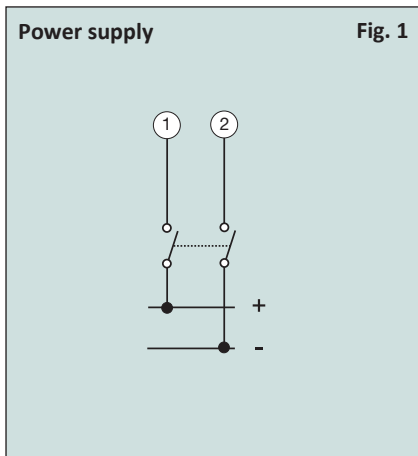
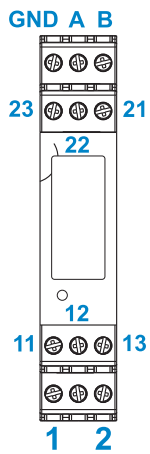

VIM-S (AV10 and AV30) connections

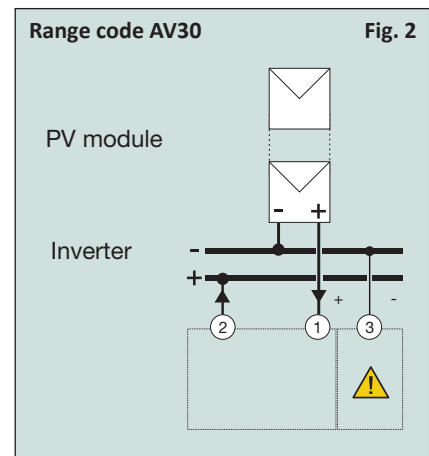
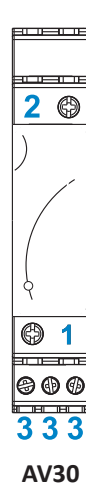
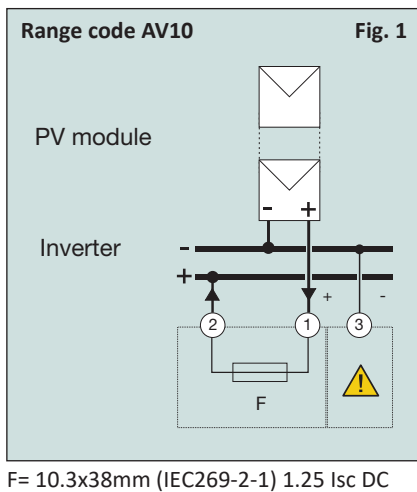
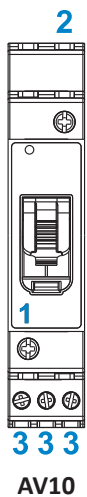

= Not power input, only for voltage signal measurement.



VIM-P connections

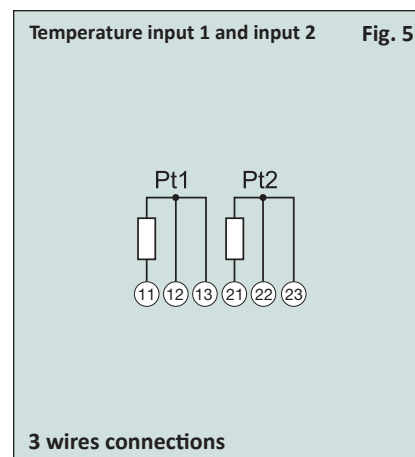
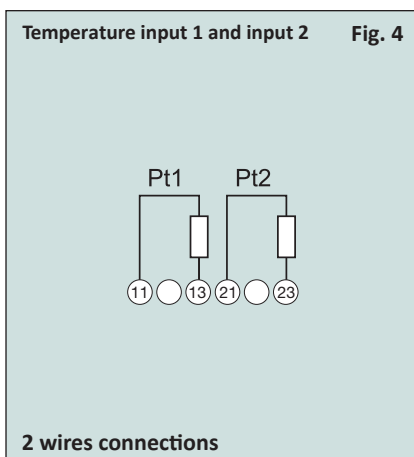
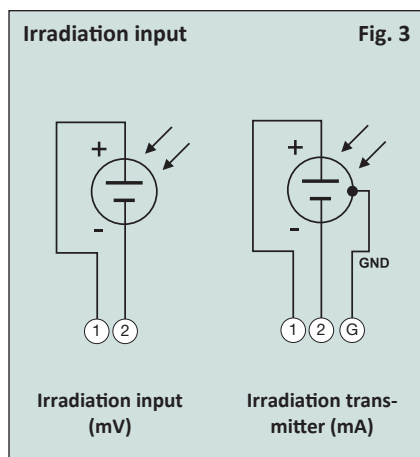
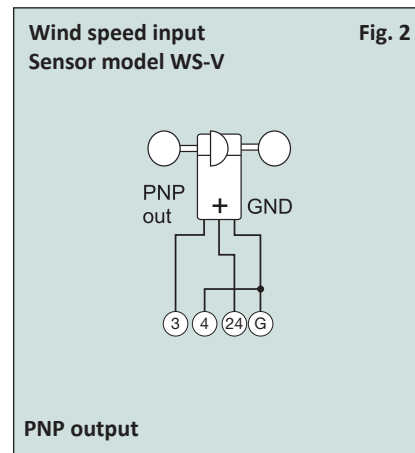
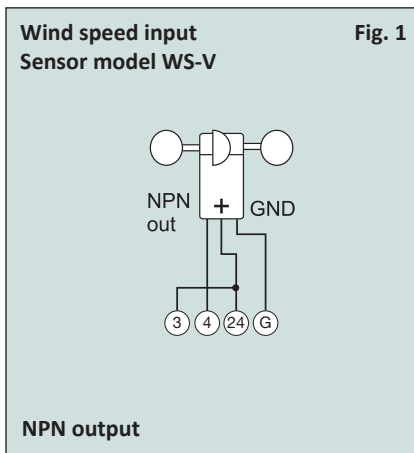
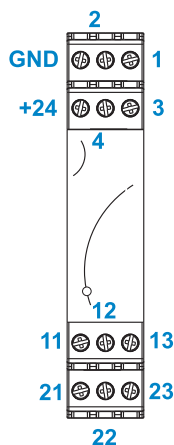

VIM-O connections

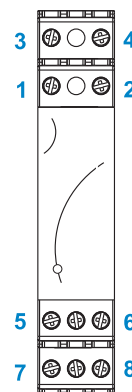
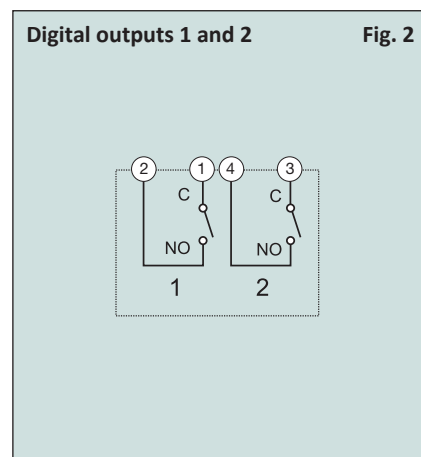
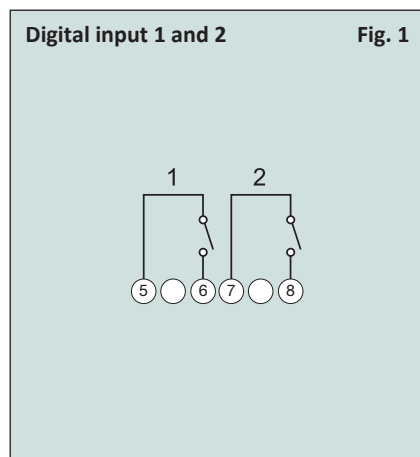



VIM-O “AT” option connections

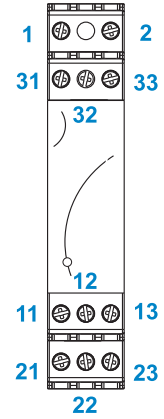
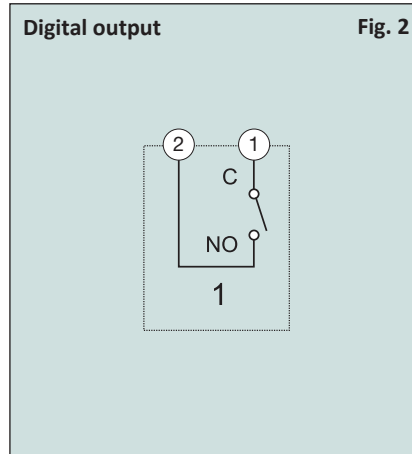
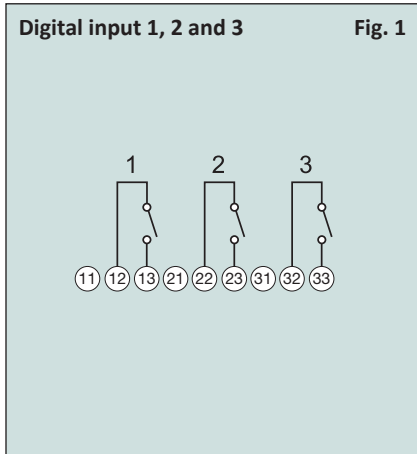

VIM-ANTI connections

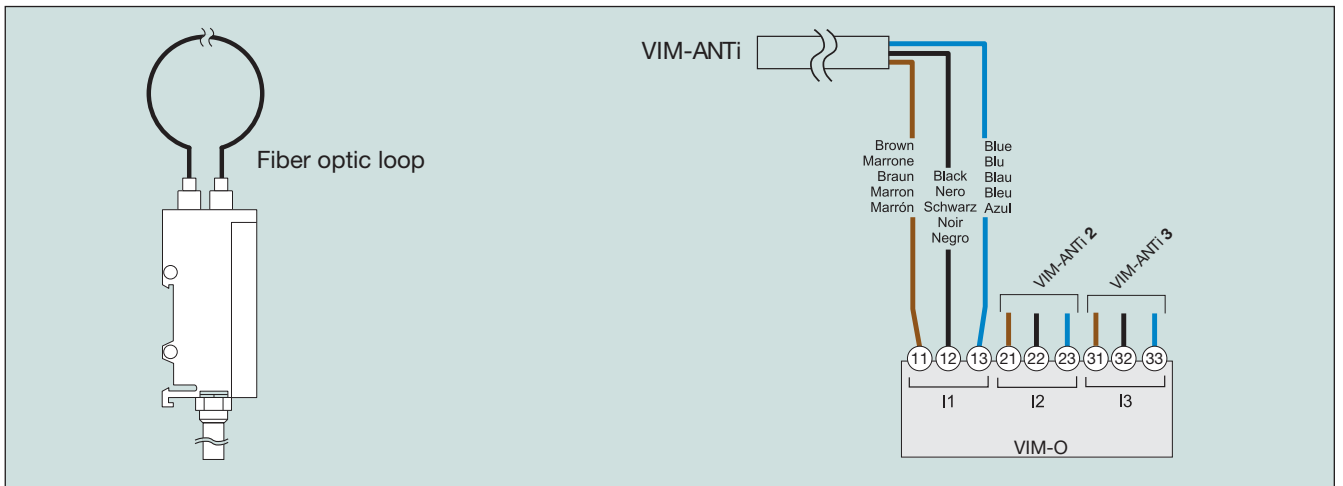

VIM-ANTI mounting and use

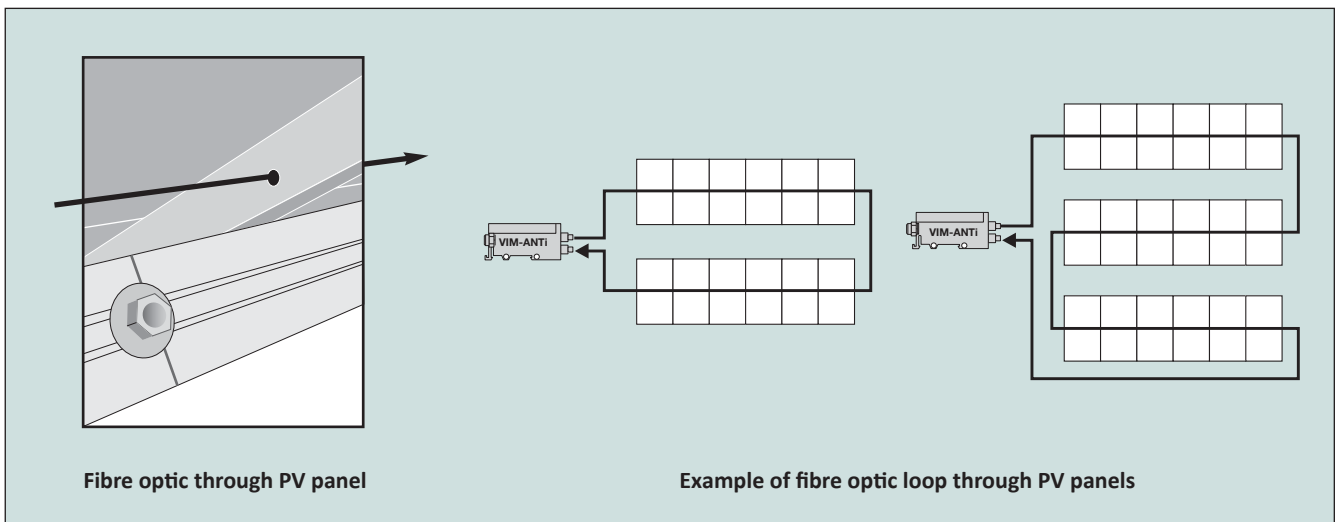



VIM-1 mounting and positioning

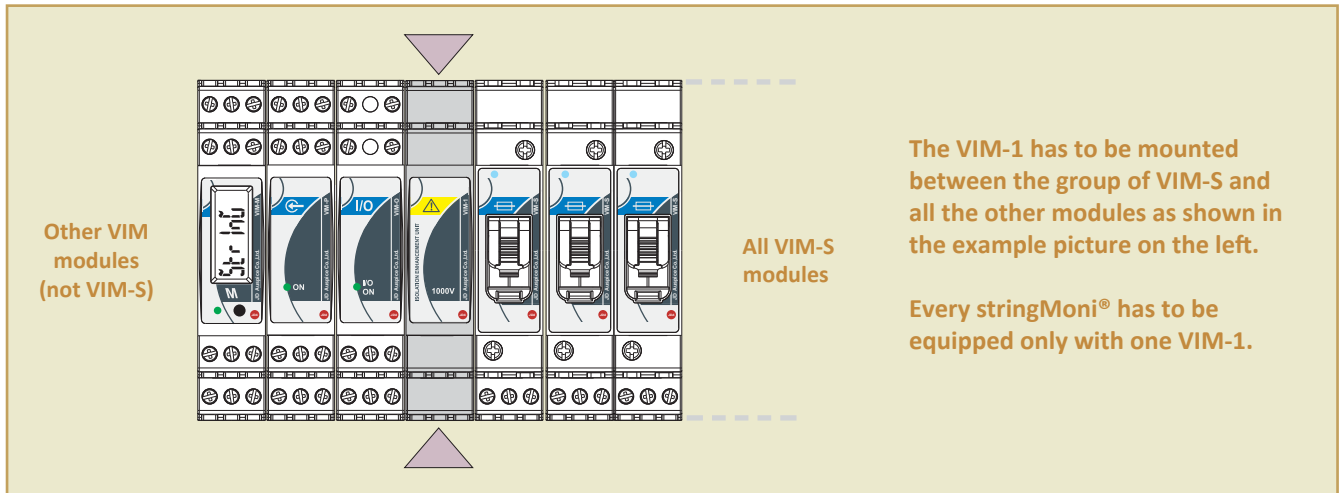

VIM-M Front panel description

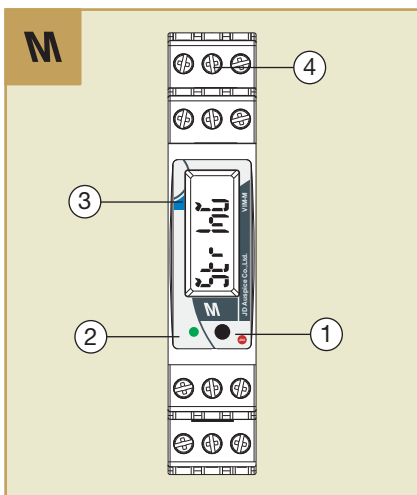

1. Push button.

To program the configuration parameters and to scroll the variables. One key function : short time pushbutton click : variable scroll or parameter increasing. Long time pushbutton click : programming procedure entering, parameter selection confirmation.

2. LED.

Green steady light : the module is power supplied and there is no communication on the RS485 bus. Green blinking light: the communication on the RS485 bus is working. Red : alarm detected (any). In case of alarm/communication condition the LED alternates its colour from red (alarm) to green. The blinking time is approx. 1 second.

3. Display.

LCD-type with alphanumeric indications to :
- display some configuration parameters;
- display some measured variables.

4. Screw terminals.

For power supply, bus and digital inputs/output connections

VIM-S Front panel description (AV10 range code : 16A)

1. LED.

Green : the power supply is ON, there is a string current up to 1A :

Yellow : there is a string current from 1.1 to 3A :

Light orange : there is a string current from 3.1 to 6A :

Orange : there is a string current from 6.1 to 8A :

Dark orange : there is a string current from 8.1 to 10A :

Red : there is a string current higher than 10A :

White : the unit is enabled by VIM-M module for data reading and displaying.

Cycling from blue to any other colour listed above (from yellow to red) : string alarm

Cycling from blue to green : blown fuse.

Cycling from blue to violet : inverted string polarity.

Cycling from white to any other colour :

the unit is enabled by VIM-M module for data reading and displaying and shows the status of the module according to the colour list above.

2. Screw terminals.

For string connections

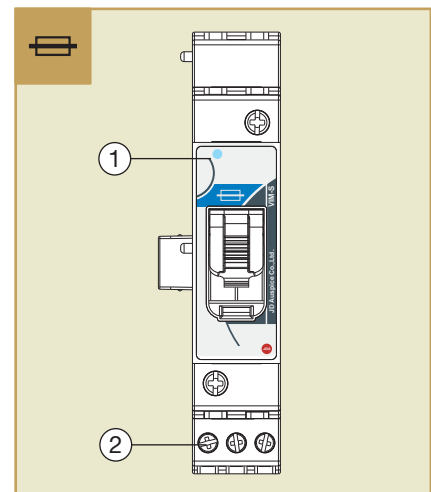

VIM-S Front panel description (AV30 range code: 30A)

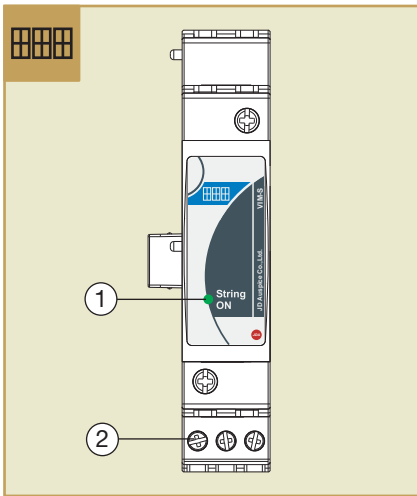

1. LED.

Green : the power supply is ON, there is a string current up to 1A :

Yellow : there is a string current from 1.1 to 6A :

Light orange : there is a string current from 6.1 to 12A :

Orange : there is a string current from 12.1 to 16A :

Dark orange : there is a string current from 16.1 to 20A :

Red : there is a string current higher than 20A :

White : the unit is enabled by VIM-M module for data reading and displaying.

Cycling from blue to any other colour listed above (from yellow to red) : string alarm.

Cycling from blue to violet : inverted string polarity.

Cycling from white to any other colour :

the unit is enabled by VIM-M module or data reading and displaying and shows the status of the module according to the colour list above..

2. Screw terminals.

For string connections

VIM-P Front panel description

1. LED.

ON steady light : the module is power supplied.

Green : the power supply is ON.

White : the unit is enabled by VIM-M module for data reading and displaying

2. Screw terminals.

For measuring input connection

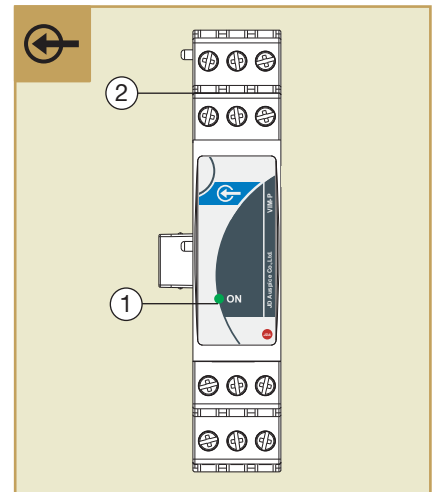

VIM-O/VIM-O AT Front panel description

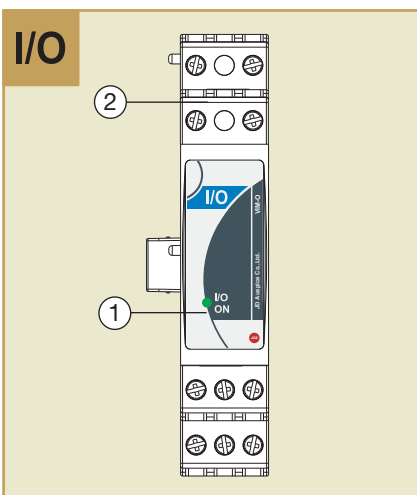

1. LED.

ON steady light : the module is power supplied.

Green : the power supply is ON

White : the unit is enabled by VIM-M module for data reading and displaying.

Red : one or up to three digital inputs are activated

Blue : one or both digital outputs are activated

Cycling from one colour to any other one :

the unit shows the status of the module according to the colour list above.

The cycling time is approx. 1 second.

2. Screw terminals.

For digital inputs and outputs connections



VIM-ANTI Front panel description

- 1. Green LED.**
The power supply is ON
- 2. Red LED.**
The optical signal loop is working
- 3. Optical fibre connectors.**
One RX and one TX optical fibre connector
- 4. One cable.**
Cable for power supply and signal output.

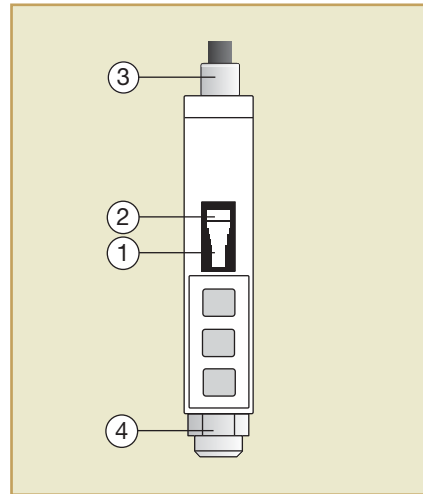

VIM-M Dimensions and panel cut-out (mm)

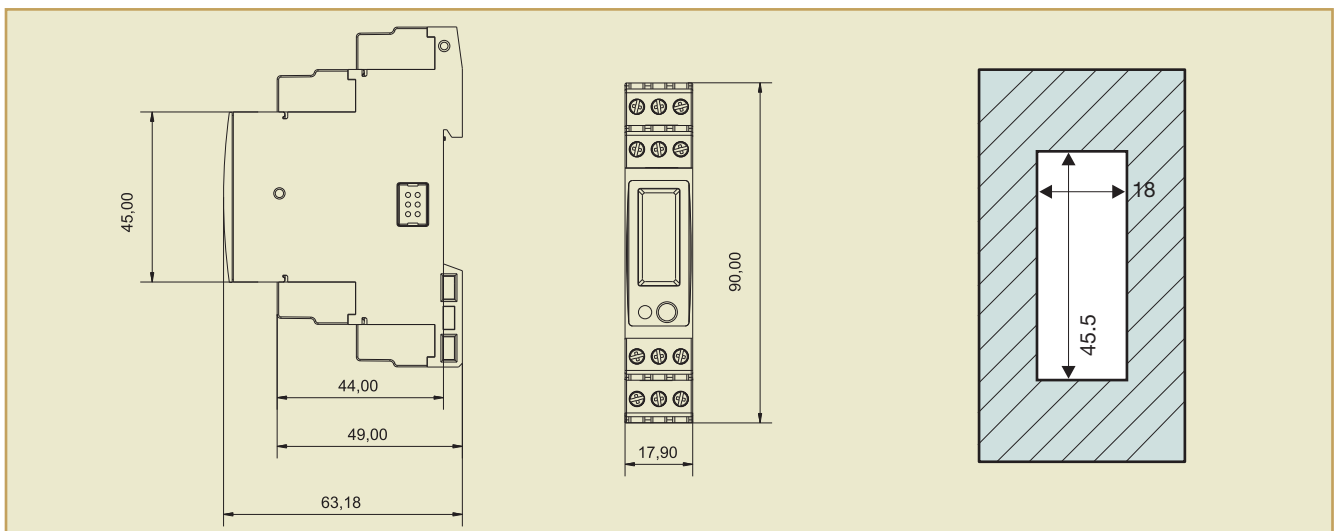

VIM-S (AV10) Dimensions and panel cut-out (mm)

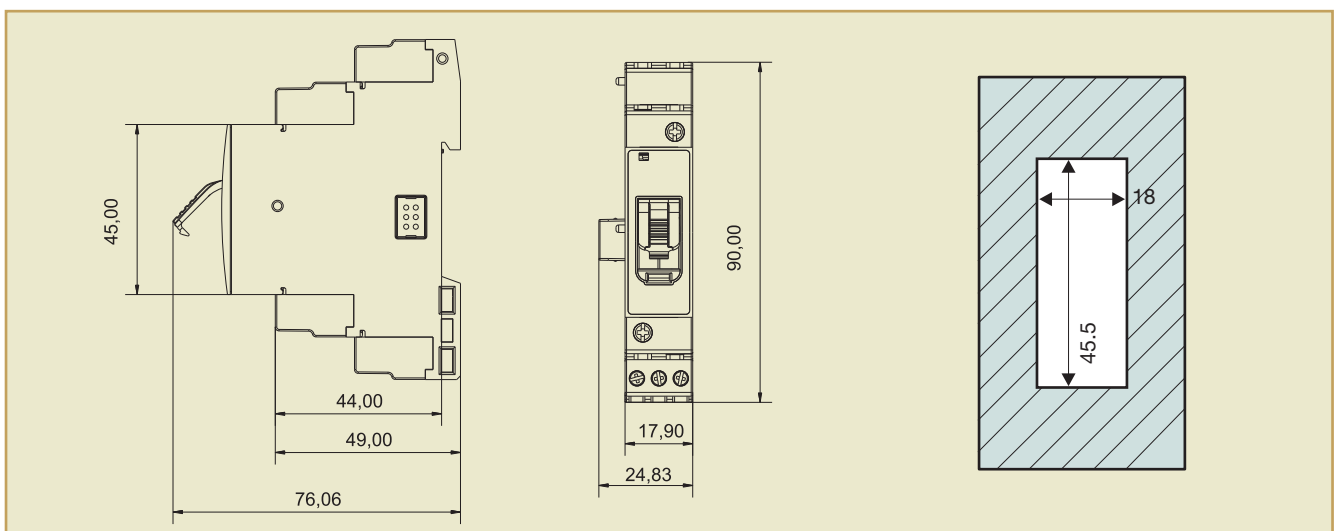



VIM-S (AV30) Dimensions and panel cut-out (mm)

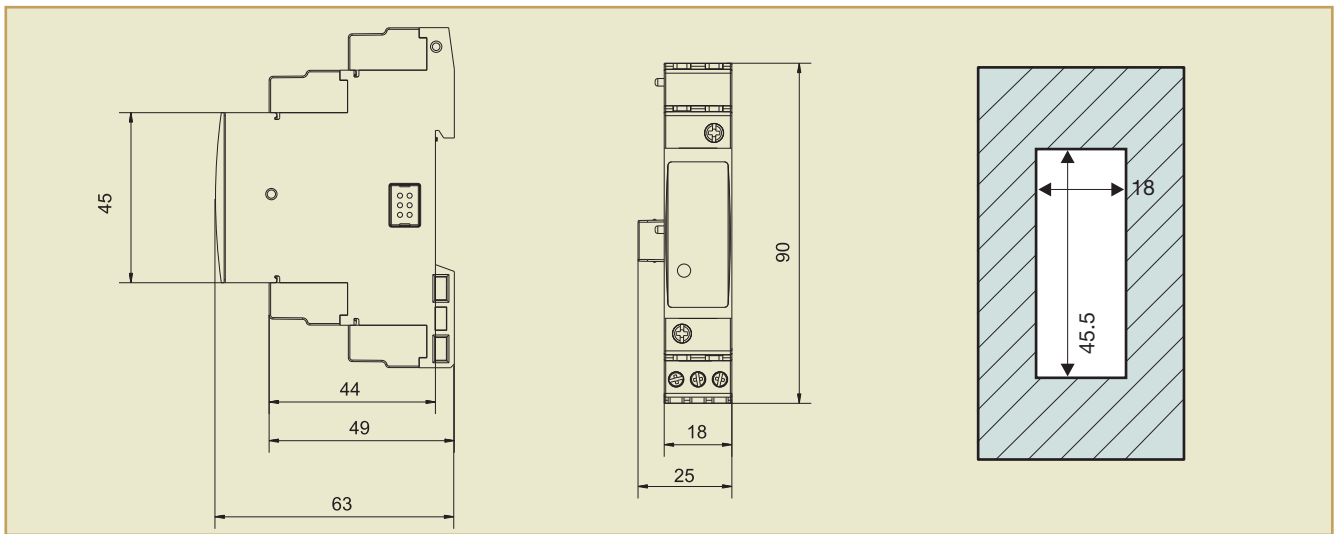

VIM-1 Dimensions and panel cut-out (mm)

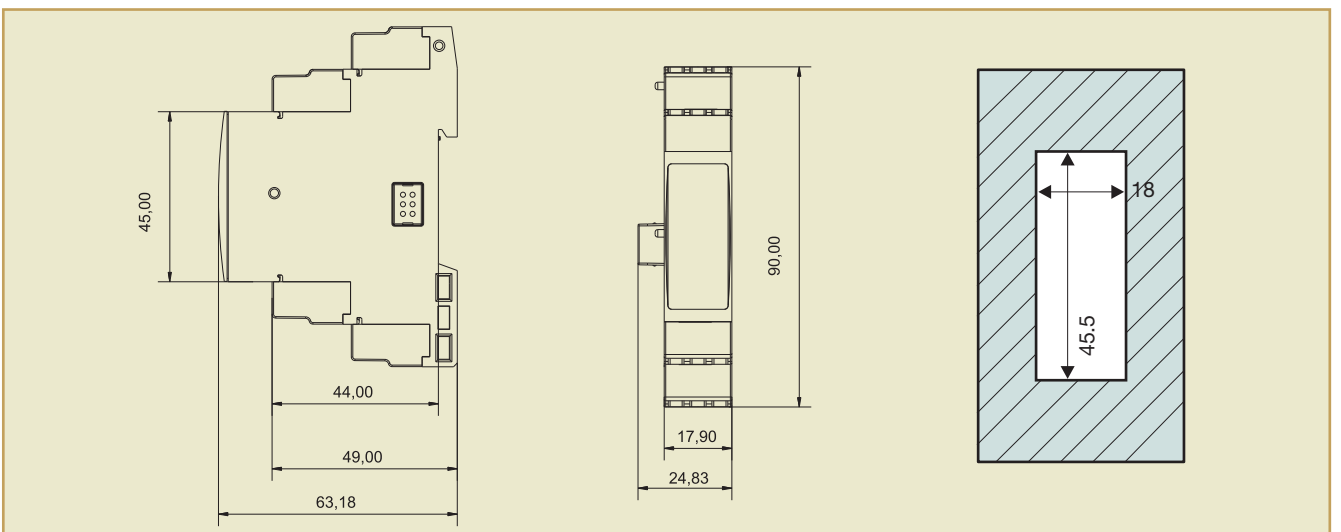

VIM-P Dimensions and panel cut-out (mm)

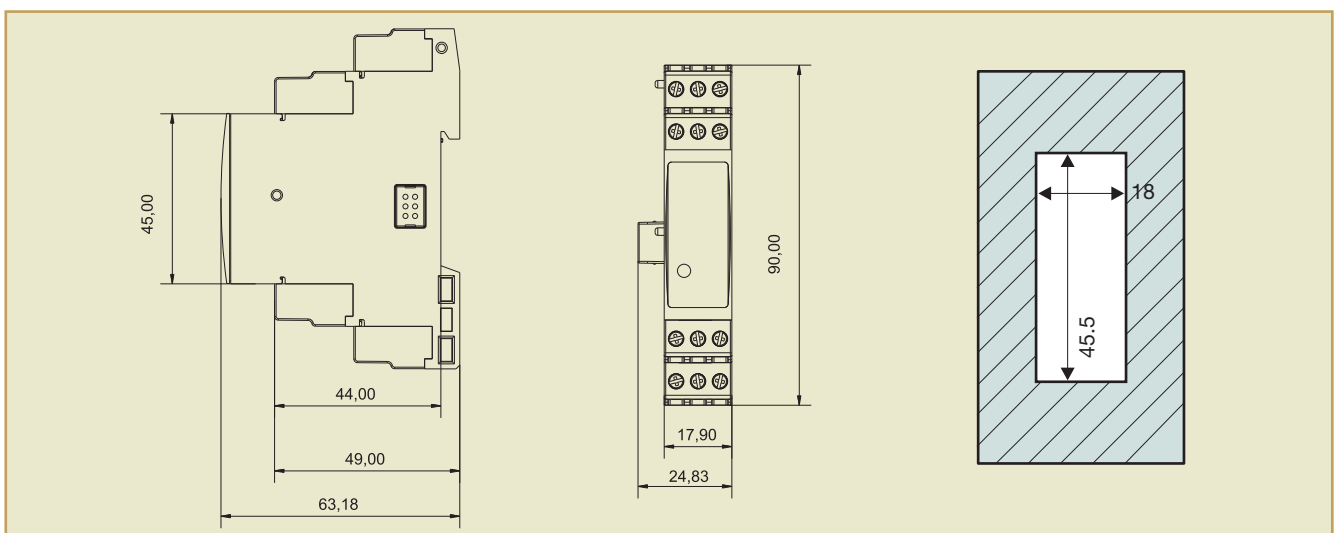

VIM-O/VIM-O AT Dimensions and panel cut-out (mm)

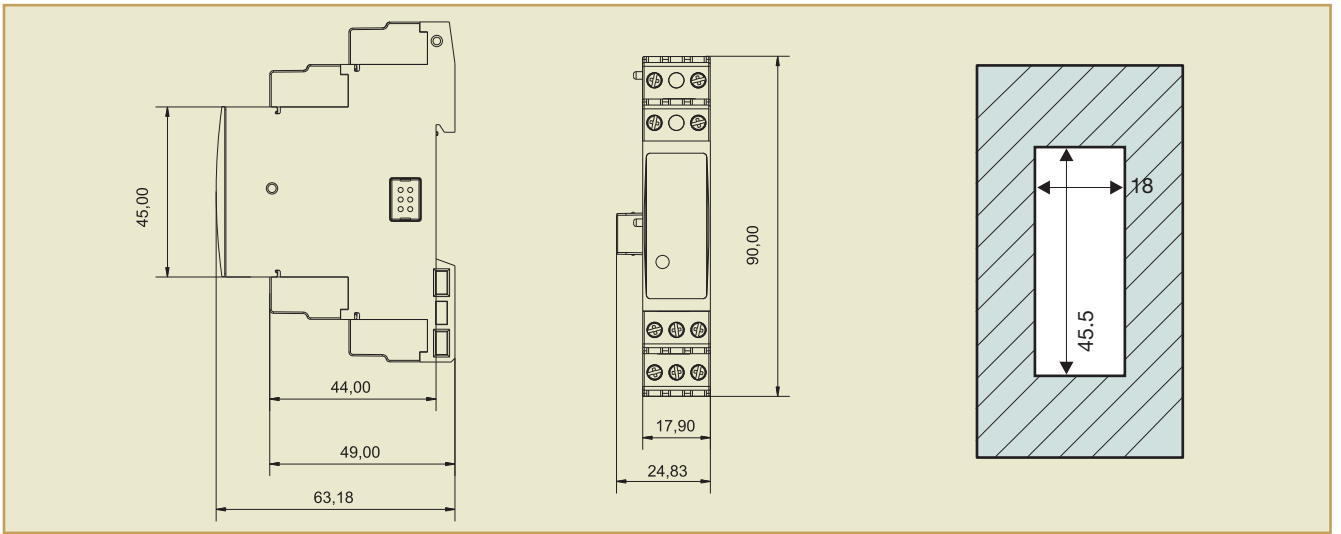

VIM-AT Dimensions (mm)

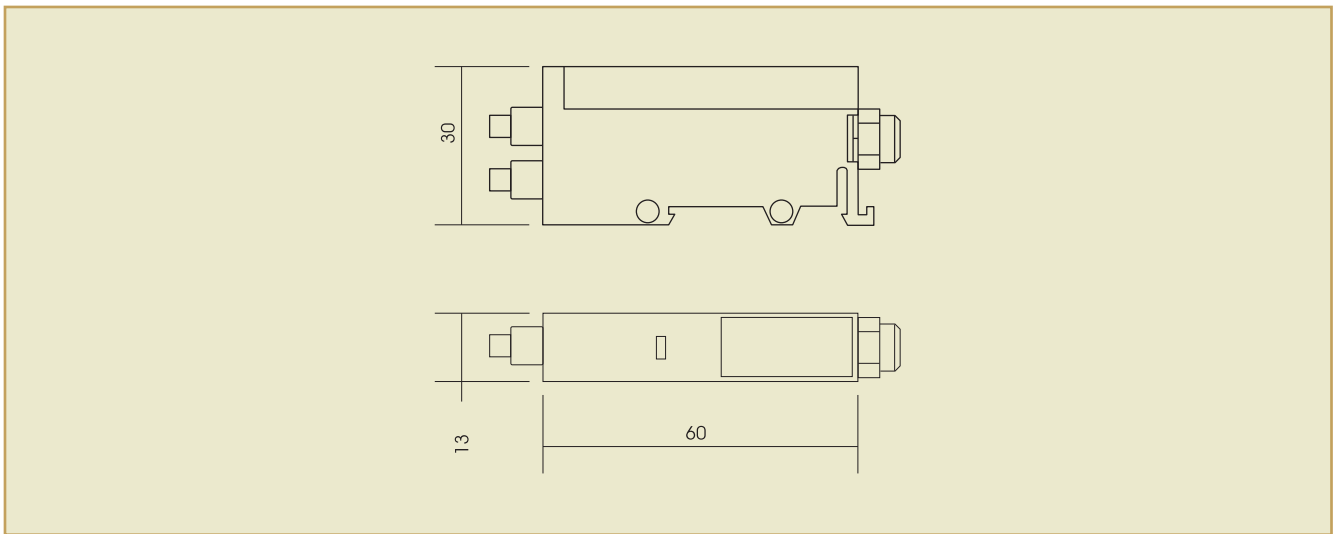



Mean time to failure (MTTF)

Model	MTTF/MTBF - Years	Test conditions	Standard
VIM-M	24.2	gf, 50°C	MIL-HDBK-217F
VIM-S	35.4	gf, 50°C	MIL-HDBK-217F
VIM-P	65.4	gf, 50°C	MIL-HDBK-217F
VIM-O	31.7	gf, 50°C	MIL-HDBK-217F

gf : ground, fixed.

stringMoni[®] parameter programming and variable reading software

stringMoni[®]Soft	Multi-language software (Italian, English, French, German, Spanish) for variable reading and parameters programming. The program runs under Windows XP/Vista/7.
Application	Up to two different applications can be selected : - Solar : a management of a limited network where stringMoni [®] Soft manages basically one VIM-M unit with relevant VIM-S, VIM-P and VIM-O modules and maybe an energy meter connected to the VIM-M digital input; - Solar extended : a management of a complex network where stringMoni [®] Soft manages many VIM-M modules and relevant subnetworks (VIM-S, VIM-P and VIM-O units) and maybe an energy meter (EM21-72D, EM24-DIN, EM26-96) connected to the same RS485 bus.
Configuration mode	There are two configuration levels : - the RS485 communication network which can include either one or more VIM-M units : - the auxiliary network with all the parameters relevant to the following modules : VIM-M, VIM-S, VIM-P VIM-O.
Data storing	In preformatted XLS files (Excel data base).
Data download	Manual or automatic at programmable intervals.
Data displaying	The following matrix is available : -String 1 : V-A-kW-kWh : -String 2 : V-A-kW-kWh : -String n : V-A-kW-kWh. -Main : PV module temperature, air temperature, irradiation and wind speed.
Alarm set-up	Alarm parameters.
Modem management	GSM/GPRS modem configuration (connected to the PC) SMS messages.

stringMoni[®]

