



日揚國際事業股份有限公司
JD Auspice Co., Ltd.



PRY-CAM

Prysmian
Group

Pry-Cam Grids Partial Discharge Monitoring system — General Description



note: subject to change without any notice, JDA pay no responsibility



Contents

1. Introduction	4
2. PD monitoring system description	4
3. Pry-Cam acquisition units	6
4. Pry-Cam Wings PD Sensors	8
5. Network devices and connections	10
5.1 Data network based on Fiber Optic	10
6. Power supply network and connections	10
6.1 Powering the system by using a dedicated LV line	10
6.2 Powering the system by using Pry-Cam Cable	10
6.3 Control Room and Server	12
7. PD monitoring Software and diagnostic database	13



1. Introduction

The Partial Discharge (PD) monitoring system has the purpose of continuously monitoring the PD activity along the entire route of the MV/HV circuit. The continuous monitoring of PD activity will provide information of the state of the line and related accessories and alarms on its wear, aging and potential damages.

The PD monitoring system is composed by several electronics devices able to continuously acquire the PD at every single accessory in the circuit. PD data will be analysed in real-time and stored in a central server. This allows the circuit supervisor or a remote operator to browse each measure and to track the PD trend for each accessory. If anomalous conditions are met, specific alarms are automatically sent to the operator.

A smart Wings PD sensor will be installed on each accessory (i.e. terminations and joints), allowing to measure its specific PD activity. A Pry-Cam Grids acquisition unit will be installed in proximity of each group of three accessories. Each Pry-Cam unit will be connected to a central server where performed measures and data will be uploaded. The server executes further processing on the gathered data so to allow a simple and effective visualization of component status and trends. The server, as well as each Pry-Cam unit, can be accessed also from a remote location to perform remote diagnosis or specific measures.

Specific deployment of the system and installation details will be chosen according to the specific condition and constraints found on the installation site.

2. PD monitoring system description

Pry-Cam PD monitoring system consists of:

- Pry-Cam Wings PD sensors installed on each network component;
- Pry-Cam Grids acquisition units, each one near a group of 3 accessories, connected to 3 local PD sensors;
- A communication network, either based on distributed Fiber Optics or UMTS modems;
- A low voltage power supplying network for Pry-Cam Grids units, either based on LV cable, local harvesters or Pry-Cam cable.

A local server should be included, to be housed close to one end of the circuit, including a server for control and storage purposes, the related UPS, communication equipment and Internet access. The diagram of a single measurement point is shown in Figure 1a. A sketch of the PD monitoring system layout is depicted in Figure 2b.

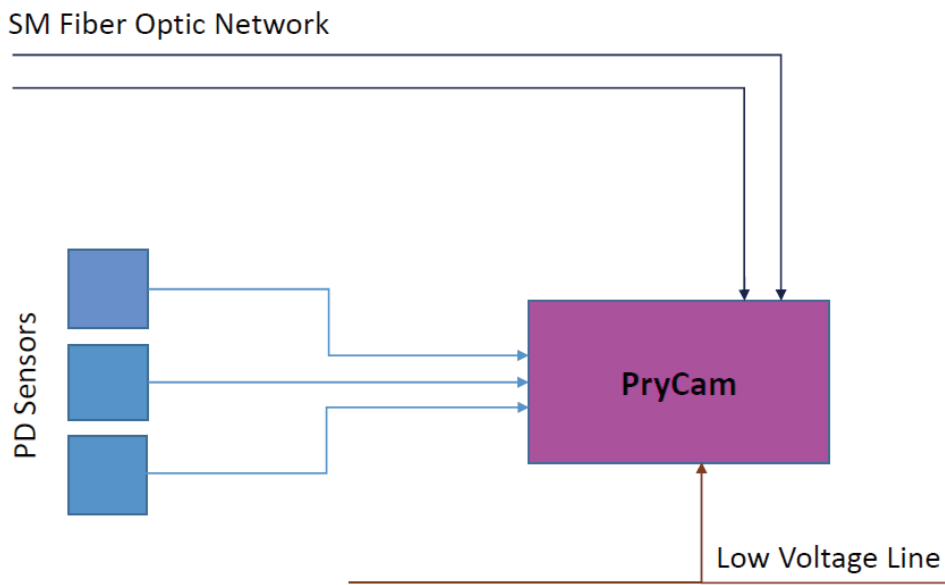

Fig.1a: Schematic of each measurement point.

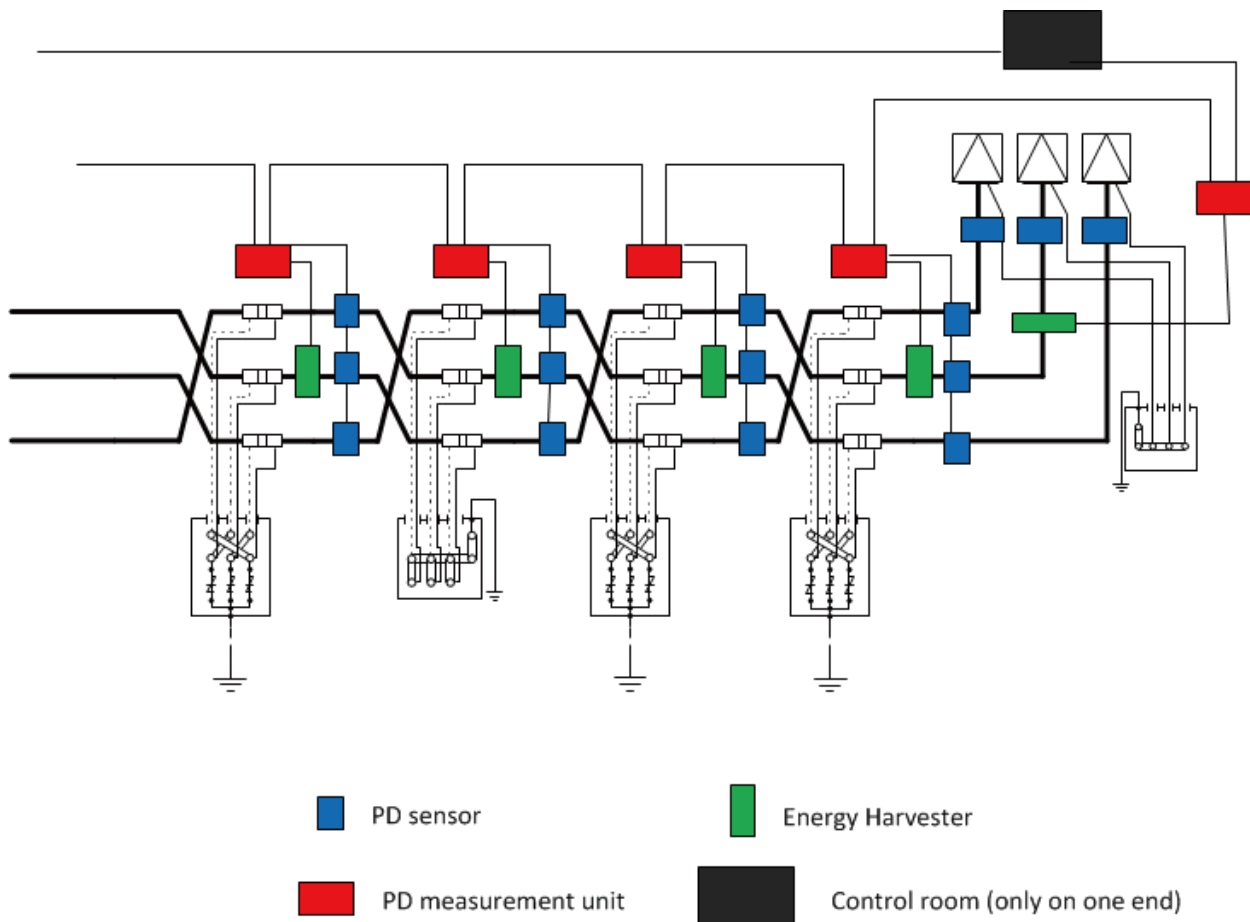

Fig. 2b: Example of layout of the PD monitoring system. Daisy Chain Version



3. Pry-Cam acquisition units

The Pry-Cam Grids is an integrated, autonomous Partial Discharge (PD) monitoring systems for electric components (cables, joints, terminations, GIS, transformers, etc.) based on the exclusive Prysmian Pry-Cam wireless sensing technology. Pry-Cam Grids make possible to monitor the conditions of High Voltage and Medium Voltage assets by continuously tracking the Partial Discharges activity. The system performs periodic PD measurements that are locally analysed, stored and sent to a remote server. The monitoring system automatically analyses each measure and send an alarm if an anomalous condition is detected. The measurements can be remotely viewed and controlled from any location via an Internet connection, this allows remote diagnoses to be made.

The Pry-Cam Grids is composed by a high-speed acquisition unit, an embedded computer handling the measurement process, analysis and communication tasks, a solid state local data storage and an optional communication module with the remote server (GPRS/UMTS or LAN connection). Each unit can handle up to 3 PD sensors.

The Pry-Cam Grids employs a high-performance data acquisition unit that allows to acquire the actual PD pulse waveforms with a time resolution of few nanoseconds. This allows to collect a very rich set of diagnostic information for every acquisition. This technology provides more information on the phenomena under test compared to other technologies (e.g. peak pulse detection, frequency band analysis, etc).

During the measurement, the control software allows the removal of environmental noise, the separation of different pulses with different shapes (and usually origins), and separately process them with classification, identification and diagnostic algorithms. This process lead to a complete assessment of all kind of defects present in the system under test.

A Pry-Cam Grids Unit is shown in Fig. 3a.



Fig. 3a: A Pry-Cam Grids acquisition unit



Table 3b summarizes the technical specification of the Pry-Cam Grids acquisition and processing unit, as well as some features.

Tab. 3b: Pry-Cam Grids technical specifications

Acquisition Unit	
Sampling frequency:	200 MS/s
Bandwidth	100 MHz
Gain:	from 0 dB to 40 dB
Trigger:	digital, configurable
Synch resolution:	16 bit (5 μ s)
Processing:	Real-time filtering, ultra-precise timestamp (5 ns)
Repetition Rate	
Full pulse waveform:	Ethernet >10,000 pps, WiFi: >3,000-6,000 pps
Pattern only:	Ethernet >50,000 pps, WiFi: >10,000 pps
Input	
PD channels:	3x100 Ohm diff., 1.5Vpp (isolated, overvoltage protected)
Synch channels:	3x1 MOhm, 5V + 1 x line (isolated, overvoltage protected)
System	
Processor:	based on ARM™ architecture
Interfaces:	Ethernet or Wireless 802.11b/g (via USB adapter)
Modem:	GSM/UMTS modem (optional)
Local storage:	Solid State Technology, up to 64GB
Working modes:	Live, remote on demand or continuous monitoring
Power supply:	110-230V, 50-60Hz AC / 12V DC
Power consumption:	< 5W
Weight:	About 400g (depending on options)
Working temperature:	From -52°C to 90°C
Dimensions:	250 x 210 x 100 mm (LxWxH)
Case:	Aluminium with IP67 protection rating
Mounting:	Flange/screw, orientation horizontal/vertical

4. Pry-Cam Wings PD Sensors

The monitoring system will employ the Prysmian PD sensors at all measurement points.

The PryCam Wings are active electromagnetic Partial Discharge (PD) sensors that have been designed to sense the electromagnetic radiation generated by PD phenomena propagating through insulating media or along conductive materials. The electromagnetic bandwidth of interest for PDs ranges from less than 1 MHz to about 50 MHz. Most of the electromagnetic energy is however usually located below 20 MHz. Due to the electromagnetic sensing principle, these PD sensors are able to detect PDs without any direct electrical or physical connection to the component under test. For this reason, they make possible to achieve an excellent degree of insulation from HV components (especially during faults) and an easy and non-invasive installation process, that can be carried out even on powered assets. Each sensor provides the high frequency PD signal and the synchronisation (phase) signal in case of AC powered assets. New Wings HD sensors also provide two additional features compared to previous models: an integrated test circuit, able to generate test pulses to check the sensor health status, and a unique electronic 64 bit serial ID for each sensor, making easy identifying, retrieving, tracking and tracing each sensor during its entire life. Wings sensors are powered by the acquisition unit with a low DC voltage and low power supply (5V DC, max. 25 mA). They feature overvoltage (surge) protection devices to prevent damage in case of line faults.

The Wings sensors are moulded in a soft silicone rubber enclosure that allows both electric insulation and protection from harsh environmental factors (water, dust, UV, etc.). The Wings sensor features a 10 m long Ethernet Cat. 5e cable and one IP67 RJ45 connector. The Ethernet Cat. 5e cable has a PolyEthilene (PE) insulation which makes the cable waterproof and also resistant to UV radiation, scrapes and high temperatures. The cable is suitable also for outdoor and buried installations.

The twisted pair cable together with the sensor active drive allow for a better immunity to noise, a reduced signal attenuation, and a better frequency response compared to commonly employed coaxial cables.

In case of need the cable length can be easily extended up to 30 m with a standard Ethernet cables, connectors and joints.

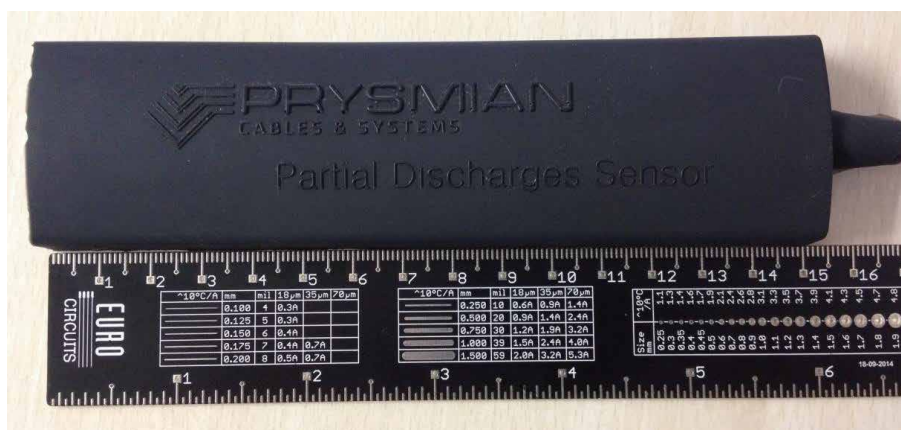

Figure 4a: Pry-Cam Wings Sensor Body



Fig. 4b: Pry-Cam™ Wings full equipment: sensor, 10 m long Ethernet Cat. 5e cable, IP67 RJ45 connector.

Technical data	Values
<i>Type</i>	Electromagnetic active sensor, also providing AC synch signal.
<i>Bandwidth</i>	0.5 – 50 MHz typical (up to 75 MHz with an attenuation < -12dB)
<i>PD sensitivity</i>	Down to 1 pC
<i>Synch sensitivity</i>	Down to about 150 VAC (at 10 cm)
<i>Synch frequency</i>	From 10 Hz to 1 KHz
<i>Self-test capability</i>	Integrated pulse generator circuit, digitally controlled
<i>Unique ID</i>	64 bit unique ID stored in the sensor NV memory
<i>Working range</i>	From contact up to 10 cm (depending on the PD activity level)
<i>Power supply</i>	3.3-5 V DC, max. 25 mA (from acquisition system)
<i>Weight</i>	About 50g (depending on options)
<i>Dimensions</i>	150 x 15 x 40 mm (LxHxW), flat and soft type
<i>Cable</i>	10 m, PE insulated Ethernet Cat 5e (suitable for outdoor, underground)
<i>Connector</i>	RJ45 in rugged IP67 enclosure with dust cap
<i>Packaging</i>	Silicone rubber, IP68 protection grade
<i>Optional parts</i>	IP68 cable joints for cable extension

Tab. 4c: Pry-Cam Wings PD sensor technical specifications



5. Network devices and connections

All the Pry-Cam units are connected to the central server by means of a data network, allowing the automatic downloading of measurement data and the direct control of each unit (if required). Two options are available for connecting the acquisition units to a common network: a) an UMTS/3G modem, b) a Fiber Optic (FO) network. These options are both described in the next paragraphs.

5.1 Data network based on Fiber Optic

In case of choice of a Fiber Optic network, a dual (duplex) singlemode/multimode fiber strand is used to connect each measurement location to the local server. According to the circuit layout and customer requirements, two options are available. The first and recommended one is to use a single mode fiber optic strand to connect each Pry-Cam Grids to the Local Server. In this case, every Grids will be served by a specific fiber and it will be connected directly to the server.

Otherwise, a multimode fiber strand can be used to connect each Pry-Cam Grids to the previous and following one in a daisy chain configuration, ending in the local server.

6. Power supply network and connections

All devices hosted in a measurement point have to be supplied with the required electrical power. A power budget of at least 5W/10W has to be considered per each measurement point. This includes the power consumption of the Pry-Cam unit, and the one of the UMTS/3G modem or Ethernet switch (if part of the system). Each measurement point may have a switchboard (bipolar) and a patch panel allowing for disconnection of the measurement point for service purpose and for distribution of the power. These components have to be dimensioned for main low voltage (240 VAC, 50Hz, max 10A, bipolar), and are used either in case of LV network or harvesting technology. The power supply components can be enclosed in an IP67 box along with the communications equipment.

6.1 Powering the system by using a dedicated LV line

A dedicated Low Voltage (LV) line can be used to power all the measurement points. This line will be deployed for the entire length of the circuit in a specific conduit with a tap at each 1.5 km for each measurement point. The line will be powered by the mains voltage (240V AC, 50Hz) at one or preferably at both ends of the circuit. The cable for the LV line will be a three-wire cable (live, neutral and earth) with a conductor section of 10 mm². The overall adsorption will be less than 400W.

Each tap from the main LV cable will be connected to the switchboard (if present) of the measurement point for powering the electronics.

The same cable duct for the LV line, once deployed, can be advantageously used also for the deployment of the FO network.

6.2 Powering the system by using Pry-Cam Cable

The system may be powered as well by means of Pry-Cam Cable. The latter is the most reliable solution for supplying power and data to the PD equipment. The Hybrid Pry-Cam Cable allows to have all FO and power supply cables for monitoring systems' needs in one solution. Additionally, thanks to its structure, it allows future installations and modifications of the system employed while relying on the very same architecture.

Pry-cam cable will be laid along main power cable and can provide:

- Power supply for Pry-Cam Grids by two phases of LV 220 AC; consumption <5W;
- Direct Fiber Optic connection (SM FO will be taken from Pry-Cam cable) to the Pry-Cam Asset Management local server;

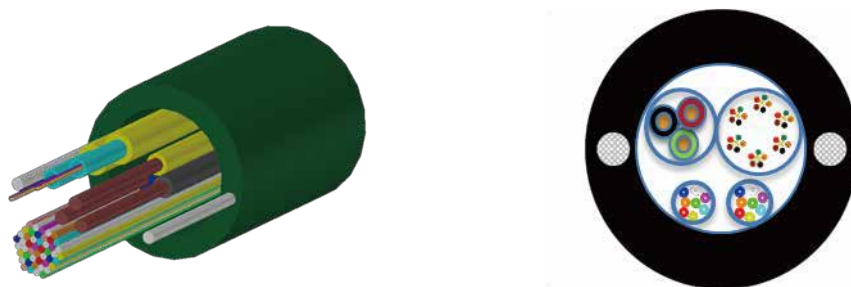

Figure 6a: Hybrid Pry-Cam Cable design

6.3 Control Room and Server

The Control Room (CR) is an indoor location hosting the measurement server and related components. These comprise an industrial PC (the server), an UPS and networking devices. It is recommended that the CR will have a controlled temperature set-up to less than 30°C. The CR and the server shall be accessible for maintenance and/or for data download if necessary. The server purpose is either to locally control the entire monitoring system, either to process and store the measurements performed by every Pry-Cam unit. Acquired data are passed to the server and stored locally in the internal database. The server performs analysis of acquired data, by means of diagnostic algorithms, in order to detect the presence of PD activity in the monitored system.

The detailed equipment list located in the CR is the following:

- A server PC,
- LCD screen, 17"
- UPS ("Uninterrupted Power Supply")
- Ethernet switch/router
- Prysmian PD monitoring software suite
- Windows (XP or subsequent) or Linux operating system (on server)
- 19" rack cabinet (dimension about 600x700x200 mm) hosting the above mentioned devices
- A broadband Internet connection (by factory LAN or dedicated modem)

Figure 8a show a sample installation of the server and related devices on a CR and the working principle.



Fig. 8a: Server installation in a Control Room.



7. PD monitoring Software and diagnostic database

Data acquired from all the measurement points are stored and managed in the server internal database. Data are constantly analysed and processed in order to detect anomalous conditions and to trigger alarms. By analysing measures taken at regular intervals it is also possible to draw trends about PD evolutions and component conditions. For each monitored component it is possible to retrieve last measurement, past measurements, trends and additional data. Either the monitoring information and the measure control parameters can be set from a simple and intuitive web interface or dedicated software. Parameters such as gain level, trigger level, acquisition frequency, alarm type and thresholds are completely programmable.

Prysmian alarm triggering system can be set in two different modes:

1a. Qmax Thresholds:

The main parameters related to alarms are the following:

1) Choice of the main PD level indicator among:

- Maximum PD amplitude (in mV or pC)
- 95% percentile of the PD amplitude distribution
- Number of detected PD per acquisition
- Number of PD per cable voltage period

2) Quick and intuitive status indication:

■ Green (no relevant condition detected); ■ Red (anomalous condition detected)

3) Customizable alarms, parameters, processing and interfacing can be implemented on Customer request.

1b. Pry-Cam Brain:

The system can be equipped with Pry-Cam Brain, a measures' clustering algorithm that allows to classify PD discharge by analyzing their pattern and waveform.

Specifically, Pry-Cam Brain algorithm is able to identify the root cause of every single pulse (corona, internal, surface caused pulse) so to flag the dangerousness of the phenomenon by raising the appropriate alarm. Such alarms are based on a traffic light approach. Specifically:

- Green – NO PD
- Yellow – Signals should be analyzed by an expert. In such cases it was not possible to classify the pulses in a unique way.
- Red – Dangerous PD.

In both mode 1a and 1b, in case of alarm the system is able to perform a basic diagnosis of the problem, in addition, remote diagnosis are available whenever the system can be remotely accessed. The local database and system can be connected on Customer request to the central Prysmian database in order to exploit some additional services such as: measurement data backup, remote diagnosis, remote measurement, and access to the Prysmian PD knowledge base to improve diagnostic indications.

During the monitoring system commissioning, Prysmian operators will perform a complete assessment of the integrity of the system, they will perform PD calibration procedure for each installed sensor (so to determine the mV/pC ratio) and they will check environmental noise level

and set properly acquisition parameters as well as alarms thresholds. Usually these set-ups don't need to be changed during circuit operations, but a periodic check-up is recommended.

Figure 9a and 9b show a screenshot of the server web interface and the control software for manual operation. Both can be accessed and used from a remote location.

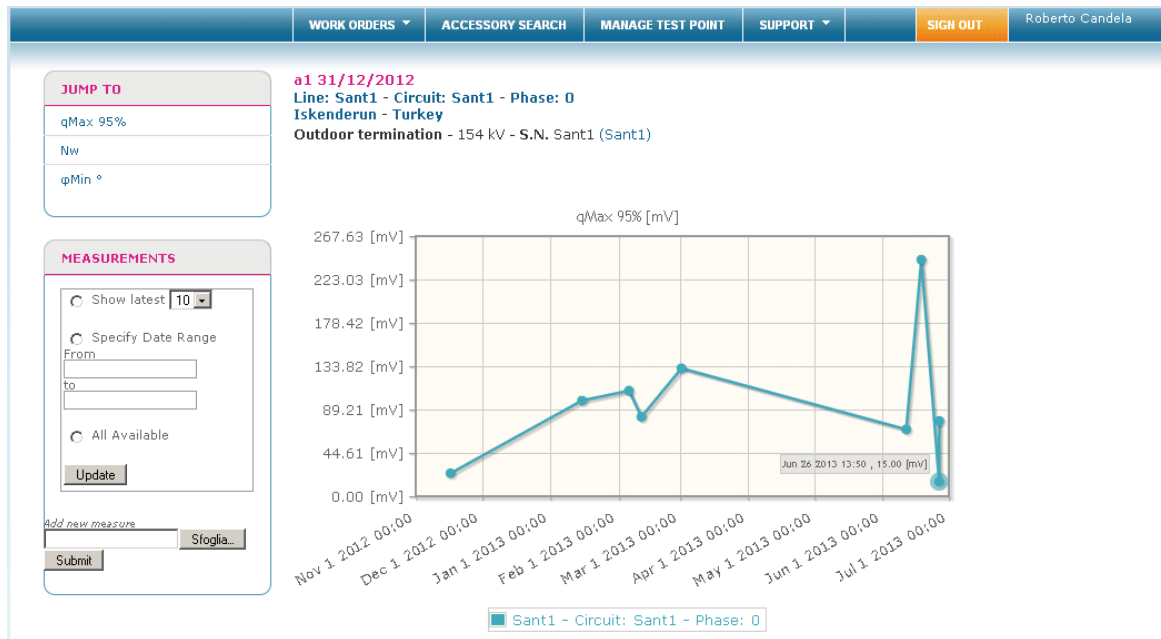

Fig. 9a: Screenshot from the server application showing PD trends.

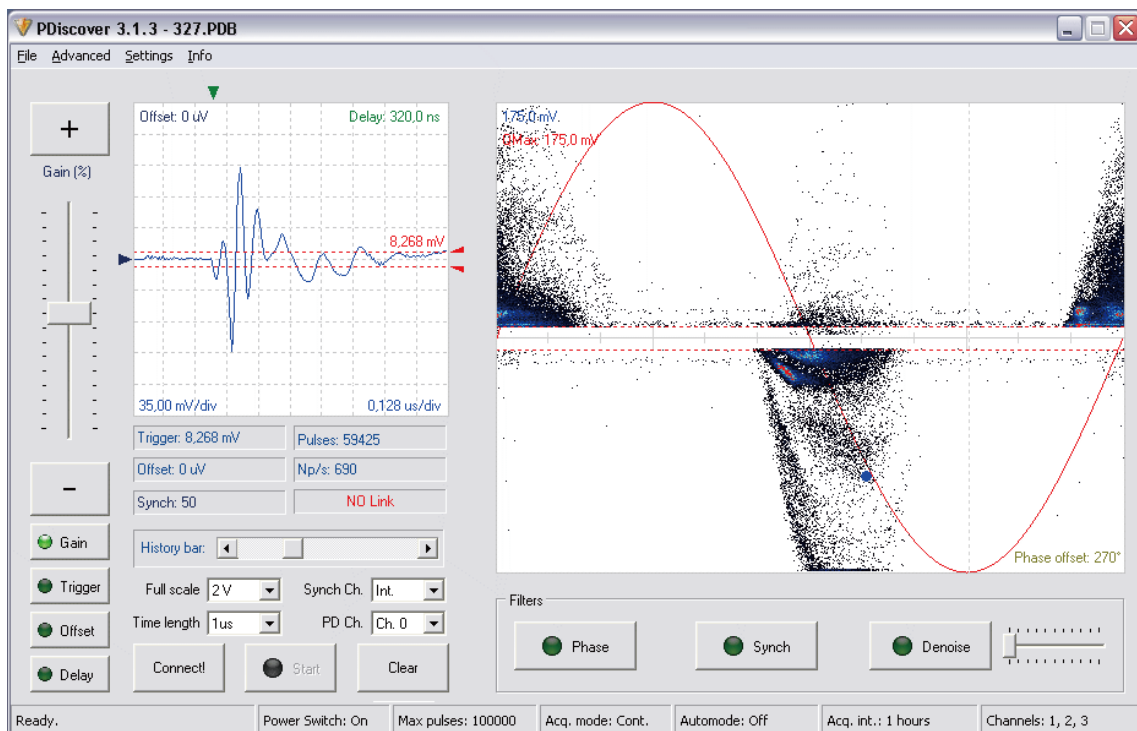

Fig. 9b: Screenshot from the control software used for manually controlled measures or set-up.



Data Visualization

The server can show the system status by means of SCADA Protocol. Already available protocols are: Modbus, DNP3, IEC60870-5-104, IEC61850 ed. 1 e 2. Together with customer, upon specific request, other communication protocol could be evaluated.

Alarms will be delivered in 4 ways:

1. Through Server Display. Basic method, available only on server display. Operator must check the server display to notice an alarm.
2. Through e-mail. The server is somehow connected to the internet. The system will send an e-mail with the troublesome situation.
3. Through SCADA.
4. Through Relays: Relays could close some contacts managed by customer management system.
5. Access through a dedicated Ethernet line.