



SUNWAY TG 750 1000V

Solar Inverter



note: subject to change without any notice, JDA pay no responsibility



SUNWAY TG 750 1000V Inverters are full digital devices for controlling photovoltaic energy conversion. Designed and manufactured in Italy by the technicians of Elettronica Santerno S.p.A. using the most advanced electronics technology.

All parameters inherent to the inverter's operation are easily programmable in a guided way through the keyboard and the alphanumeric display. Parameters are organized in a menu structure.

ADVANTAGES

- Very high conversion efficiency with a single power conversion stage, optimized for minimum losses
- Construction modularity and cabinet industrialization for a simplified service on field.
- Grid Code integrated features (LVRT, Reactive Power Control, Frequency and Voltage control) as per most advance European and WW standards
- Remote monitoring possibility with REMOTE SUNWAY'M software both for a single machine and a multi inverter installation.
- Wide range of inverter sizes available.
- Integrated DC side protection with under load breaker with automatic disconnection
- Integrated miss wiring protection on DC side
- up to 16 fuse-protected DC inputs
- Integrated AC side protection with under load breaker with automatic disconnection
- Integrated active monitoring of DC isolation.
- Integrated EMC filters.
- Integrated keypad and display
- Integrated Modbus on RS485 and TCP-IP on Ethernet data connection
- Integrated inputs for environmental sensors
- Diagnostic messages on alphanumeric display that allow quick setting of parameters during start up and immediate monitoring during the operation.
- Easily accessible components for maximum reliability and maintainability.
- Possible use of photovoltaic modules that require an earthed pole.
- Thorough manufacturing with first class materials, all Made in Italy.

Caratteristiche generali / Main features	
Model	SUNWAY TG 750 1000V
PV field voltage range	550 ÷ 820 Vdc
Open-circuit voltage	1000 Vdc
Rated output voltage	340 Vac ± 10%
Output frequency	47.5 ÷ 52 Hz
PV voltage ripple	<1%
Total AC current distortion	≤3%
Utility interactive features	Embedded, software controlled, to be configured as per applicable grid code
Protection against DC overvoltages (SPD)	YES
Degree of protection	IP44/Nema 1 for indoor model - IP54/Nema 3R for outdoor
Operating temperature range	- 100°C +500°C -13°F +122°F
Relative humidity	95% non-condensing
Tropical climate protection	All electronics PCB coated for best protection against harsh environment
Max installation altitude (for higher altitude contact tech support)	3000 m
Losses when stopped/Night losses	40W /0W
Anticondensation heater power consumption	1kW
Auxiliary power	Not needed - self supplied
Technical Standard	IEC 62109-1, IEC 62109-2
Cooling system	Forced air 7.500m ³ /h self controlled
Cooling system supply	2,2 kW peak power - 0,8 kW average power
Environmental sensors	6 embedded inputs
Digital communication channels	2xRS485 with Modbus + Ethernet with TCP/IP
Insulation voltage to ground and between input and output	2,5 kV to 50Hz, 100% tested on production
Thermal protection	Integrated, 5 sensors, both on cabinet and power stack
Input Ratings	
Suggested peak power	800 kWp
Rated DC input power	726,3 kW
Rated DC input current	1253,4 A (dc)
Maximum short circuit PV input current	1650,0 A(dc)
Low Voltage Output Ratings	
Minimum AC power to start/stop operation	5,0 kW
Max continuous AC rated output power (Ouput voltage +10%)	776,4 kW
Rated AC output power	707.0 kW
Rated AC total power	745,0 kWA
Min Power Factor	0,9 lead/lag
Rated output current	1201 Arms
Inverter efficiency	
Maximum Efficiency	98,5%
European Efficiency	98.1%
CEC Efficiency	98.4%
Dimensioni / Dimensions	
Inverter dimensions (LxHxD)	2600x2475x800 mm
Inverter Weight (kg)	2100 kg



Operating description

The inverter is connected to the PV field through subfield paralleling panels (String Box) that form the PV generator, and to the electric grid through an interface switch. Once the open circuit voltage of the field is enough, the inverter synchronizes with the electric power grid, closes the paralleling contactor and according to the available power on field ($P_{field} = V_{dc} \cdot I_{dc}$) it imposes to the grid a sinusoidal current in phase with the network voltage.

Main normative references

SUNWAY TG series inverters have been developed, designed and constructed in accordance with the requirements of the most used worldwide standards for Solar Inverters, including the European low voltage directives (LVD) and of electromagnetic compatibility (EMC) directives, the IEC standards, UL and CQC. Moreover, the product complies with the most advanced Grid Code to be connected with medium and high voltage distribution grid.

IMMUNITY :	Proof of immunity to electrostatic discharges according to EN61000-4-2 Levels: 6kV for contact discharge 8kV for air discharge
	Proof of immunity to fast transients according to EN61000-4-4 Levels : 2kV/5kHz PV field 2kV/5kHz serial RS232
	Proof of immunity to impulse according to EN61000-4-5 Levels: 1kV + pole/- pole PV field side 2kV + pole/earth PV field side 2kV - pole/earth PV field side 2kV + pole/earth AC side 2kV - pole/earth AC side
	Emissioni Condotte: EN55011 gruppo 1 classe B
PRODUCT STANDARD & LVD	IEC 62109-1, IEC 62109-2
GRID CODE :	CEI 0-21,CEI 0-16 (Italy) BDEW (Germany) CQC (China) UL 1741 and IEEE 1547 (USA)

Included accessories

All inverters are supplied with user manuals, technical documentation conforming to existing regulations, keys and lifting hooks, dedicated pallets for easy and safe transport.

TG 750 1000 V's block schematics

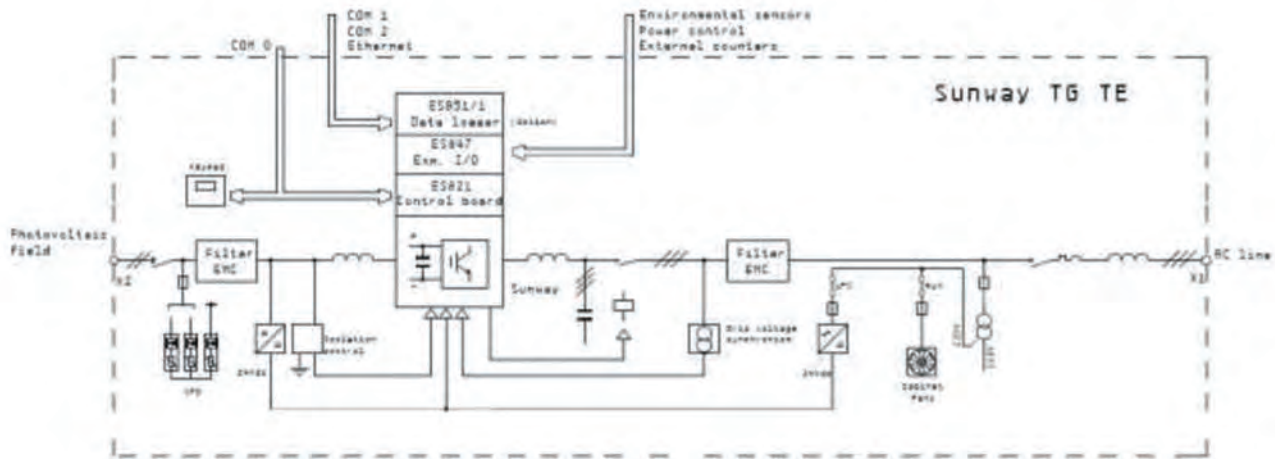

Figure 1: Block schematics

The **SUNWAY TG 750 1000V** inverters include the following functional blocks:

DC input unit

The DC input unit allows connecting the inverter to the photovoltaic generator. It is provided with under load switch, input EMI filters and SPDs. It checks the ground isolation of the Pv generator.

Static converter

The Static Converter comprises the forced switching IGBT stack and the control board. The Static Converter implements the most advanced features of the inverter, such as the control logics, the current and voltage measures, the interface protections integrated into the control software, the autodiagnosis functions and the serial communications.

AC output unit

This AC Output Unit comprises control devices, such as Contactor for the connection to the grid that can operate as an Interface Device (please refer to the heading "Control Devices"), the sinusoidal filters and the output EMI filters.



Main Integrated Standard Functions

The main standard functions implemented by the SUNWAY TG 750 1000 V are detailed below.

- Max. 6 environmental inputs monitoring solar radiation sensors, temperature sensors and wind sensors.
- Constant check for PV isolation.
- Protection against short-circuits; overvoltage and undervoltage protection for maximum reliability.
- Protection against overvoltage in the PV field input.
- Protection against PV polarity mismatch.
- Interface protection integrated into the inverter software.
- Digital input for external grid supervisor.
- Phase synchronization of carrier frequency for multi-inverter plants.
- External power supply for the ventilation system to maximize the energy delivered to the grid.
- Full integration with the remote monitoring system offered from Santerno for performance detection and trip logs.
- Full accessibility to the remote control service, both in local mode and remote mode, via laptop and via SunwayPortal.

Efficiency curve and values

Efficiency Chart between 600Vdc and 820Vdc

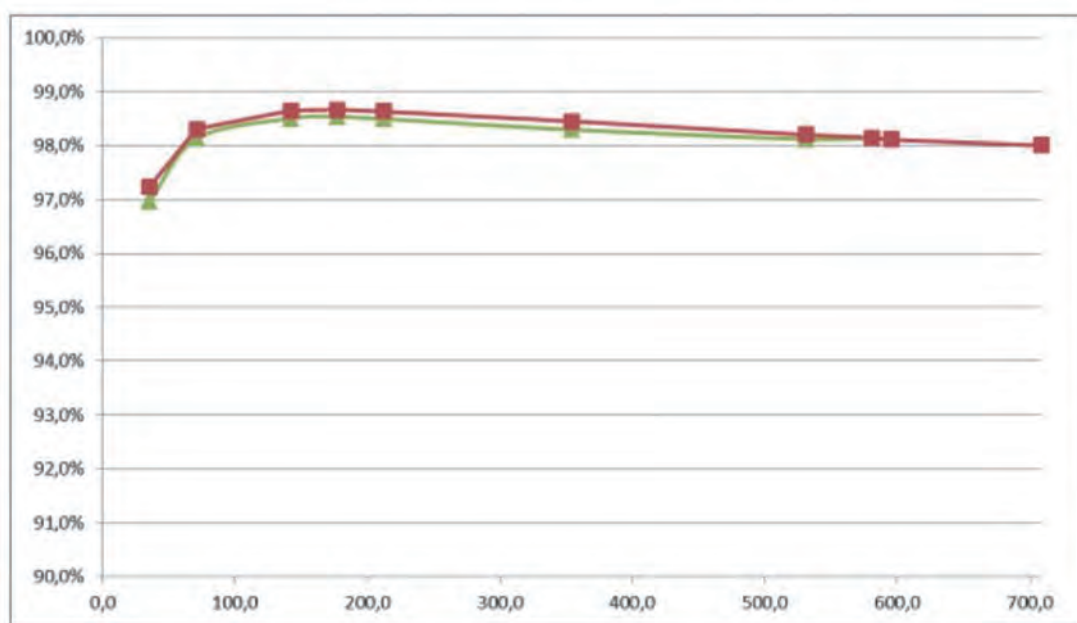

Rated Current Derating

If the ambient temperature exceeds the maximum allowable temperature (50°C), and the power of the equipment approaches its maximum value, the inverter limits the output current in order to protect its internal components from overheating. Figure 4 shows the graph indicating the maximum power delivered based on ambient temperatures (valid for equipment installed at sea level).

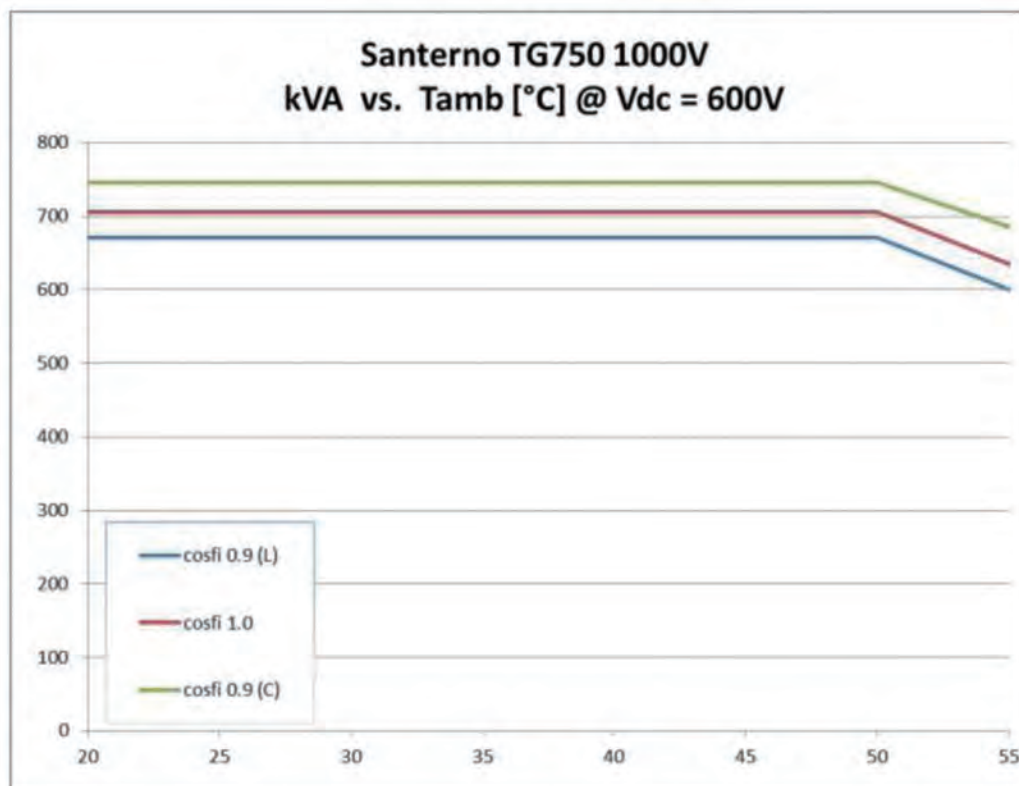

Figure 4: Temperature derating (installation altitude below 1000mt)



Pressure flow details (Inlet & outlet) if any to maintain the air flow rate and preferred ducting arrangement by Santerno

Inverters shall be located inside an independent room, properly cooled as specified below, without any other significant heating sources excepting the inverters themselves. In case of forced air cooling system, an air flow rate of 12000 m³/h shall be guaranteed by means of weather-proof air extractors for each inverter. Air extractors shall be placed close to the respective inverters, shall not permit water entrance into the cabin (drops or sprays) and a segregation system shall be applied to avoid the flow short-circuit condition with the incoming external air. The incoming air openings dimensions in the cabin walls shall guarantee an air speed of 3m/sec maximum and a EN779 G3 class filter shall be applied (the supplier will review the civil design of the cabin).



日煬國際事業股份有限公司
JD Auspice Co., Ltd.



 www.jdauspice.com



 [@jdauspice](https://www.facebook.com/jdauspice)



 ID : @jdapv

