



# SR15-A1

Analogue first class pyranometer with millivolt output and heater

*SR15-A1 is a high-accuracy solar radiation sensor. It is "first class" according to the WMO guide and ISO 9060:1990 standard and "Spectrally Flat Class B" in the 2018 revision. With its on-board heater, it is compliant in its standard configuration with the requirements for "Class B" PV monitoring systems of the new IEC 61724-1:2017 standard.*



**Figure 1** SR15-A1 first class pyranometer with heater



**Figure 2** SR15-A1 pyranometer mounted in POA (Plane Of Array) on a mast for PV performance monitoring

## Introduction

SR15-A1 is a solar radiation sensor that is applied in general high accuracy observations. It measures the solar radiation received by a plane surface from a 180 ° field of view angle. This quantity, expressed in  $W/m^2$ , is called "hemispherical" solar radiation. SR15-A1 pyranometer can be employed outdoors under the sun, as well as indoors with lamp-based solar simulators. Its orientation depends on the application and may be horizontal, tilted (for plane of array radiation) or inverted (for reflected radiation).

## PV system performance monitoring: compliant with IEC class B

IEC 61724-1: Photovoltaic System Performance Monitoring - Guidelines for Measurement, Data Exchange and Analysis - requires heating for Class B monitoring. SR15-A1, with its on-board heater, offers Class B compliance without the need for additional accessories.

Copyright by Hukseflux. Version 1802. We reserve the right to change specifications without prior notice  
Page 1/3. For Hukseflux Thermal Sensors go to [www.hukseflux.com](http://www.hukseflux.com) or e-mail us: [info@hukseflux.com](mailto:info@hukseflux.com)

### Improved measurement accuracy

Calibration of SR15-A1 pyranometer has been improved; our latest calibration method results in an uncertainty of the sensitivity of 1.8 %, compared to typical uncertainties of higher than 2.8 % for this pyranometer class. SR15-A1's zero offset  $a$  is 5 W/m<sup>2</sup> unventilated. SR15-A1's response time is < 10 s, a significant improvement relative to earlier sensors.

### Suggested use

- PV system performance monitoring
- general solar resource monitoring
- indoor simulated solar testing
- meteorological networks

### Your benefits

- best measurement accuracy in first class
- improved response time
- with on-board heater: compliant with IEC 61724-1 Class B in its standard configuration

### SR15-A1 specifications

Measurand	hemispherical solar radiation
ISO classification	first class pyranometer spectrally flat class B pyranometer (2018)
IEC 61724-1 compliance	meets Class B PV monitoring system requirements
Calibration uncertainty	< 1.8 % (k = 2)
Calibration traceability	to WRR
Spectral range	285 to 3000 x 10 <sup>-9</sup> m
Sensitivity (nominal)	10 x 10 <sup>-6</sup> V/(W/m <sup>2</sup> )
Analogue output	millivolt
Response time	< 10 s
Zero offset $a$	5 W/m <sup>2</sup> unventilated
Rated operating temperature range	-40 to +80 °C
Temperature response	< ± 2 % (-10 to +40 °C)
Heater	1.5 W at 12 VDC
Standard cable length	5 m
Levelling	optional spring-loaded levelling, with / without tube mount

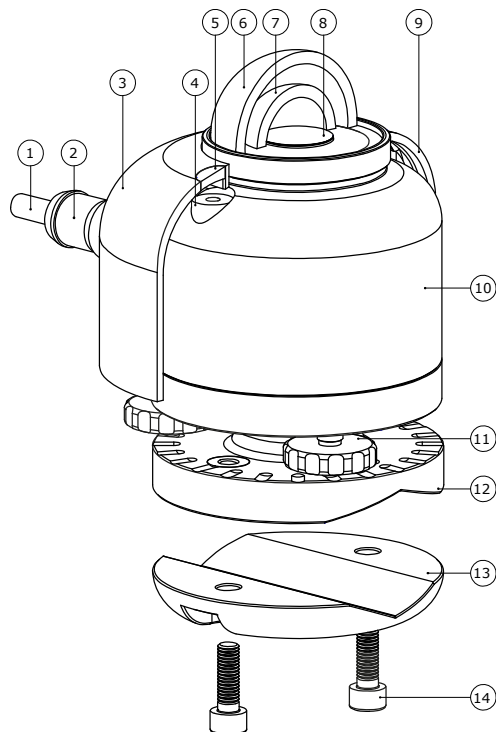

**Figure 3** overview of SR15-A1: (1) cable, (2) connector, (3) sun screen, (4) bubble level, (5) bubble level window, (6) outer dome, (7) inner dome, (8) thermal sensor with black coating, (9) quick release system of sun screen, (10) instrument body, (11) levelling feet, (12) optional spring-loaded levelling mount, (13) optional tube mount, (14) screws included with tube mount

### SR15-A1 design

SR15-A1 first class pyranometer with heater employs a thermal sensor with black coating, two glass domes and an anodised aluminium body.

### Use in National Networks

WMO, the World Meteorological Organization, recommends use of first class pyranometers such as SR15-A1 for network operation.

### Use as sunshine duration sensor

WMO has approved the "pyranometric method" to calculate sunshine duration from pyranometer measurements in WMO-No. 8, Guide to Meteorological Instruments and Methods of Observation. This implies that SR15-A1 may be used, in combination with appropriate software, to estimate sunshine duration. This is much more cost-effective than using a dedicated sunshine duration sensor. Ask for our application note.

### Options

- adapted sensitivity range
- spring-loaded levelling; practical for easy mounting, levelling and instrument exchange on flat surfaces
- tube levelling mount with set of bolts
- with PMF01 bracket for tilted installations
- longer cable; 10 and 20 metres length
- 20 metres extension cable with 2 connectors

**See also**

- **SR30** next level pyranometers for IEC 61724-1 class A PV monitoring systems
- **SR15 digital series** first class pyranometers
- **SR05**, an economical solution often used for monitoring small scale PV systems and large (agro-)meteorological networks
- view our complete [range of solar sensors](#)



**Figure 4** several mounting options are offered with SR15-A1, such as this spring-loaded levelling mount for easy mounting, levelling and instrument exchanges on flat surfaces



**Figure 5** SR15-A1 with optional tube levelling mount

**Standards**

Applicable instrument classification standards are ISO 9060 and WMO-No. 8. Calibration is according to ISO 9847. PV related standards are ASTM E2848 and IEC 61724-1.

**Uncertainty evaluation**

The uncertainty of a measurement under outdoor conditions depends on many factors. Guidelines for uncertainty evaluation according to the "Guide to Expression of Uncertainty in Measurement" (GUM) can be found in our manuals. We provide spreadsheets to assist in the process of uncertainty evaluation of your measurement.

Our pyranometer [selection guide](#) assists you in choosing the right instrument. Whatever your application is: Hukseflux offers the highest accuracy in every class at the most attractive price level.

**About Hukseflux**

Hukseflux Thermal Sensors offers measurement solutions for the most challenging applications. We design and supply sensors as well as test & measuring systems, and offer related services such as engineering and consultancy. With our laboratory facilities, we provide testing services including material characterisation and calibration. Our main area of expertise is measurement of heat transfer and thermal quantities such as solar radiation, heat flux and thermal conductivity. Hukseflux is ISO 9001 certified. Hukseflux sensors, systems and services are offered worldwide via our office in Delft, the Netherlands and local distributors.

Interested in this product?  
 E-mail us at: [service@jdauspice.com](mailto:service@jdauspice.com)