



## Hybrid HBI® HBI 50/ HBI 100 / HBI 250 / HBI 500



### HBI® battery inverter is designed for large volume storage system to

1. Firm unstable solar power to increase grid power quality, or to
2. Increase the usage of solar energy and reduce grid electricity cost, or to
3. Serve as back up power supply for local electrical equipments during grid power outage, or to
4. Serve as temporary power supply for remote area or certain events

### Features

- Touch Screen LCD
- Flexible Battery Type (li-ion, lead-acid)
- Comprehensive Protection for Inverter and Battery
- Multiple Working Mode Presetable
- Battery For cast (discharge time, capacity, etc)
- CAN and RS485 Communication Interface, Modbus Protocol
- Seamless transfer between on and off grid (optional)
- Flexible design, multiple inverters parallelable
- Build-in transformer for grid isolation (for model below 500kW)

## Typical Application

### Hybrid HBI® System/Back-up Application

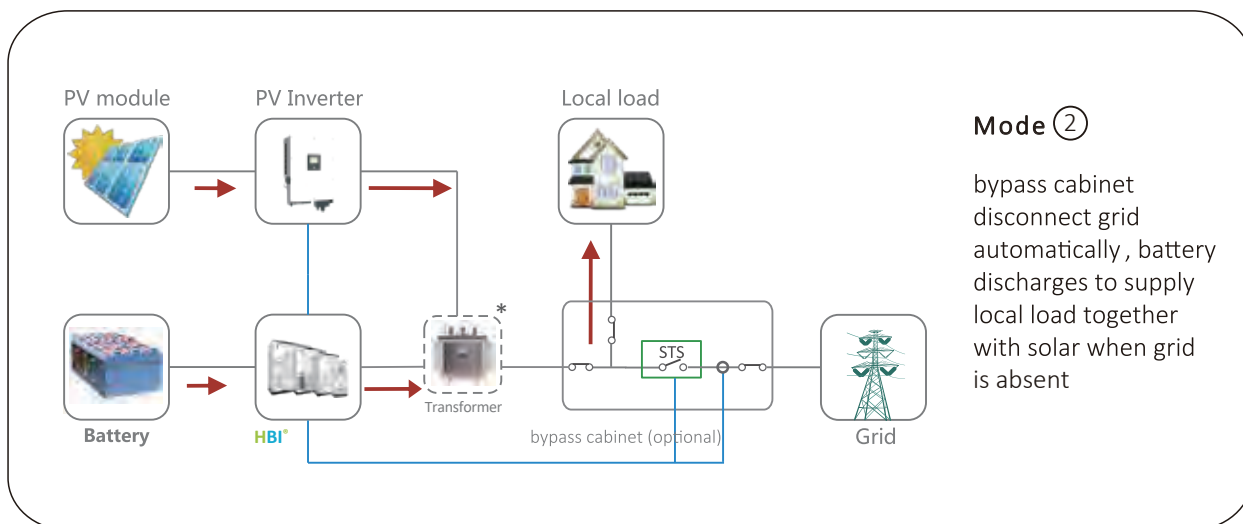
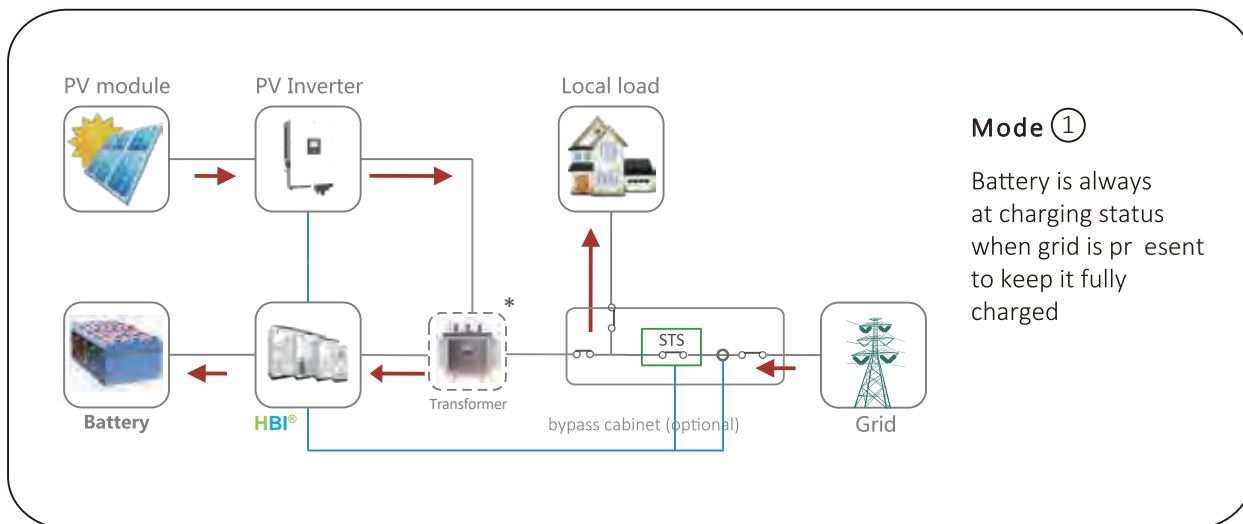

NOTE:

\*only for HBI 500

- Energy flow
- Communication
- Power cable



### AC(Grid-connected)

	HBI 50	HBI 100	HBI 250	HBI 500	
Rated power	50KV A	100KV A	250KV A	500KV A	500KV A
Rated voltage	400V	400V	400V	315V	400V
Voltage Range	310V - 450V	310V - 450V	310V - 450V	250V-362V	320V-460V
Rated frequency	50/60Hz	50/60Hz	50/60Hz	50/60Hz	50/60Hz
Frequency range	47~51.5/57~61.5Hz	47~51.5/57~61.5Hz	47~51.5/57~61.5Hz	47~51.5/57~61.5Hz	47~51.5/57~61.5Hz
THDI	<3%	<3%	<3%	<3%	<3%
PF	0.9lagging~0.9leading	0.9lagging~0.9leading	0.9lagging~0.9leading	0.9lagging~0.9leading	0.9lagging~0.9leading
Output from	3/N/PE	3/N/PE	3/N/PE	3/N/PE	3/N/PE

### General Information

Maximum efficiency	95.5%	97.1%	97.3%	97.5%	97.5%
Environment compatibility	IP20	IP20	IP20	IP20	IP20
Noise	<65dB	<65dB	<65dB	<65dB	<65dB
Environment temperature	-25 °C ... +55 °C	-25 °C ... +55 °C	-25 °C ... +55 °C	-25 °C ... +55 °C	-25 °C ... +55 °C
Cooling	Air Forced	Air Forced	Air Forced	Air Forced	Air Forced
Humidity	0 ~95% non-condensing	0 ~95% non-condensing	0 ~95% non-condensing	0 ~95% non-condensing	0 ~95% non-condensing
Altitude	5000m(derated above 3000m)	5000m(derated above 3000m)	5000m(derated above 3000m)	5000m (derated above 3000m)	5000m (derated above 3000m)
Dimension (W/D/H)	600/800/1630 mm	1100/850/1890 mm	1600/850/2080 mm	2000/850/2180 mm	2000/850/2180 mm
Weight	450KG	820KG	1465KG	1620KG	1620KG
Transformer	Low frequency	Low frequency	Low frequency	Not included	Not included
Transfer between on/off grid	Manual(default) Automatic(optional) ≤ 20ms	Manual(default) Automatic(optional) ≤ 20ms	Manual(default) Automatic(optional) ≤ 20ms	Manual(default) Automatic(optional) ≤ 20ms	Manual(default) Automatic(optional) ≤ 20ms

### AC(Off-grid)

Rated voltage	400V ac	400V ac	400V ac	315Vac	400Vac
THDU	≤ 1%linear	≤ 1%linear	≤ 1%linear	≤ 1%linear	≤ 1%linear
Rated frequency	50/60Hz	50/60Hz	50/60Hz	50/60Hz	50/60Hz
Overload capability	110%-10 mins 120%-1 min	110%-10 mins 120%-1 min	110%-10 mins 120%-1 min	110%-10 mins 120%-1 min	110%-10 mins 120%-1 min

### DC(battery)

Max power	55KW	110KW	275KW	550KW	550KW
Current regulation	± 1%	± 1%	± 1%	± 1%	± 1%
Voltage regulation	± 1%	± 1%	± 1%	± 1%	± 1%
Voltage ripple	<3%	<3%	<3%	<3%	<3%
Current ripple	<2%	<2%	<2%	<2%	<2%
Rated voltage	600V	600V	600V	600V	700V
Voltage range	500-820V	500-820V	500-820V	500-820V	600-900V
Rated current	84A	180A	460A	920A	723A
Max current	125A	220A	550A	1100A	870A
Input numbers	1	1	1	1	1

### Communication

Display	Touch Screen LCD	Touch Screen LCD	Touch Screen LCD	Touch Screen LCD	Touch Screen LCD
Communication interface	RS485/CAN	RS485/CAN	RS485/CAN	RS485/CAN	RS485/CAN



## Typical Application

### Hybrid HBI® System/Peak-shaving Application

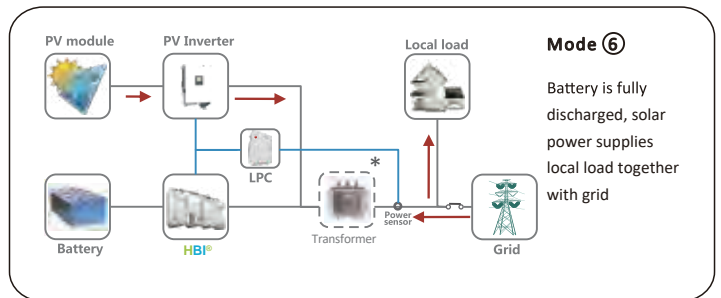
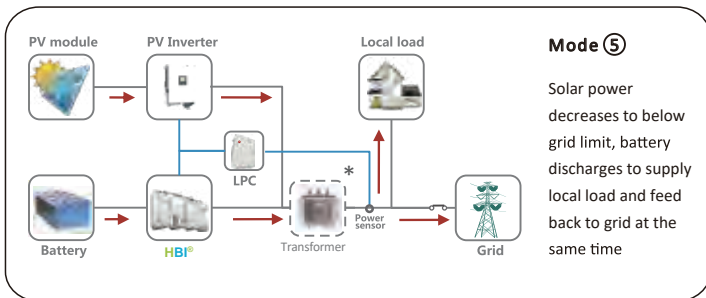
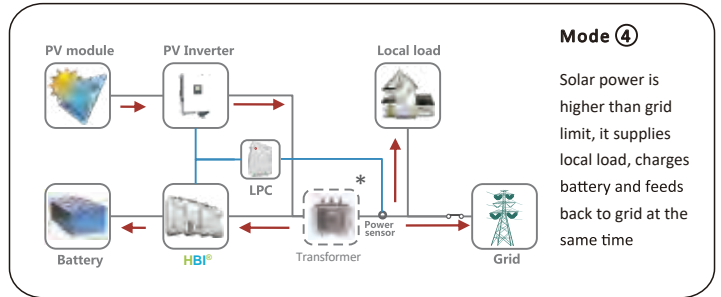
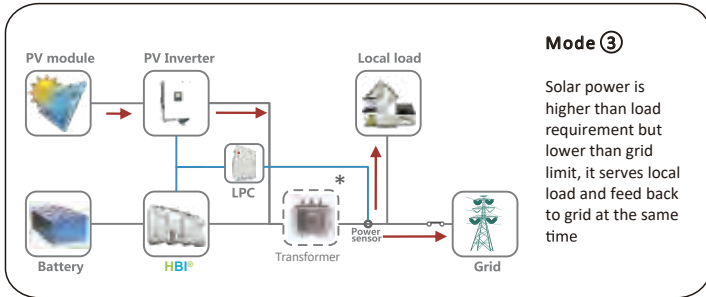
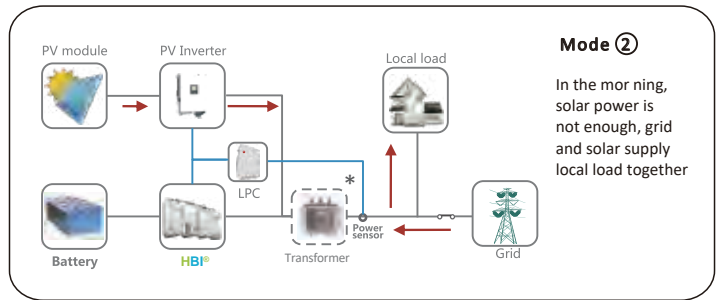
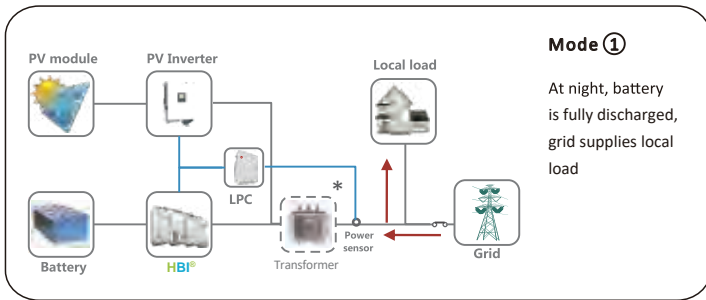
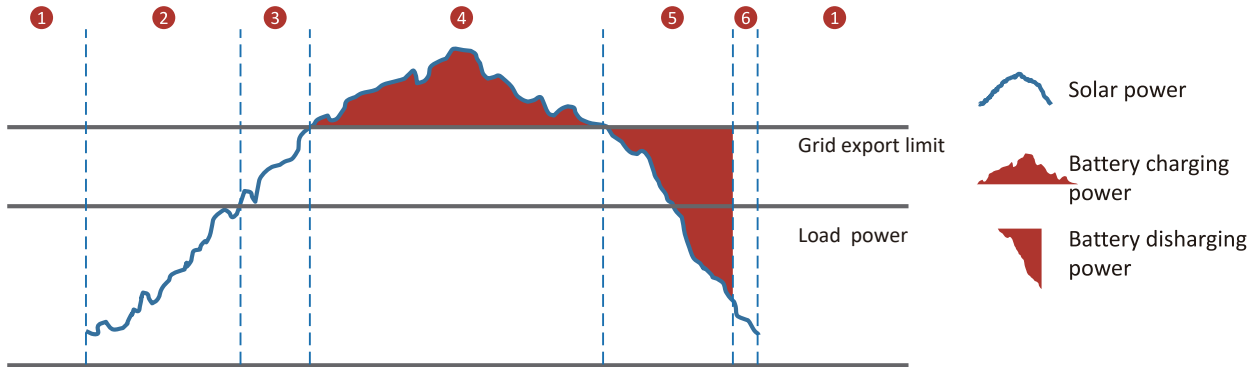

**NOTE:**

1. Output power of inverter and HBI can be controlled by the feedback information from power sensor value adjustable

\*Only for HBI 500

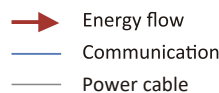



日揚國際事業股份有限公司  
JD Auspice Co., Ltd.



 [www.jdauspice.com](http://www.jdauspice.com)



 [@jdauspice](https://www.facebook.com/jdauspice)



 ID : @jdapv

