



**Calibration**

The probe calibration is performed by comparison with a second class pyranometer by using a solar simulator with appropriate filters that reproduce the solar spectrum at AM 1.5 (air mass index 1.5).

**Specifications:**

Typical sensitivity:	20 $\mu\text{V}/(\text{W}/\text{m}^2)$
Measuring field:	0-2000 $\text{W}/\text{m}^2$
Spectral range:	400nm-1100nm
Response time:	<0.5 s
Nonlinearity:	<1%
Stability:	< $\pm$ 2% per year
Temperature drift:	< $\pm$ 0.15%/ $^{\circ}\text{C}$
Calibration uncertainty:	<3%
Response according to the cosine law:	$\pm$ 3% for angles between $0^{\circ}$ - $75^{\circ}$
Working temperature:	$-40^{\circ}\text{C}$ + $65^{\circ}\text{C}$
Impedance output:	25 $\Omega$

**PURCHASING CODES**

**LP Silicon-PYRA 04:** Pyranometer with silicon photodiode with 5m fixed cable and open wires on the cable end.

The probe can be connected the series of converters/amplifiers:

- HD978TR3 and 978TR5 for the 4-20 mA output.
- HD978TR4 and HD978T6 for the 0-10 Vdc output.

**LP BL:** Base with level (for the LP 471 Silicon-PYRA probe, the base with level is assembled in the factory when ordering)

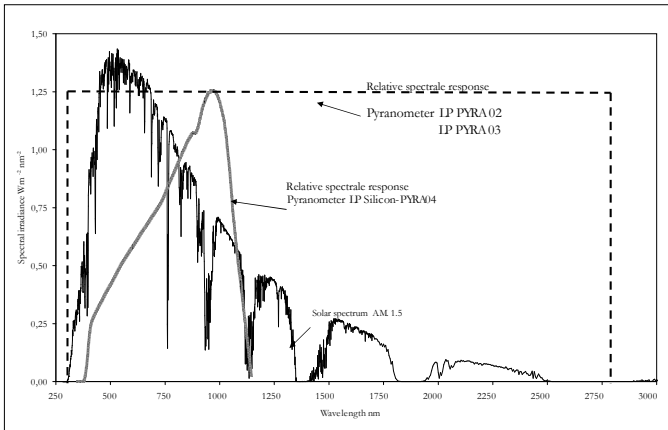

Figure 4

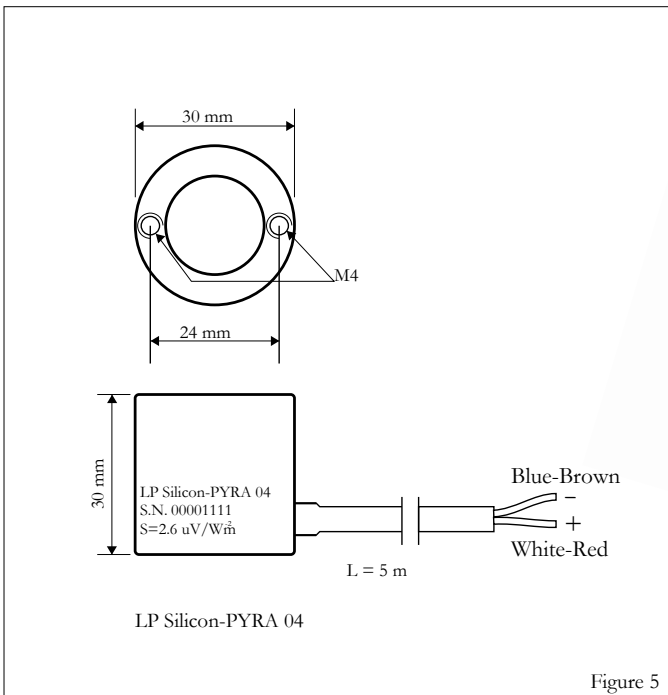

Figure 5



LP Silicon-PYRA 04 + LP BL



# LP Silicon-PYRA 04



## LP SILICON-PYRA 04 PYRANOMETER

The LP Silicon-PYRA 04. pyranometer measures the global solar radiation (W/m<sup>2</sup>) by using a silicon photodiode (400nm-1100nm). The special geometry and the diffuser allow to have a pyranometer field of view of 180 degrees according to cosine law. The pyranometer is suitable for the measurement of natural sunlight. Under conditions of overcast sky or measures reflected light is recommended to use a thermopile pyranometer (model LP PYRA 03 or LP PYRA 02). The LP Silicon-PYRA 04 pyranometer can be used in measurements of solar radiation in the field of renewable energies such as solar thermal and solar photovoltaic. The base with level LP BL (provided as an accessory) can be used to facilitate the assembly and placement in plan level. Figure 1.

The photocurrent generated by photodiode is converted into a voltage by the shunt resistance. The wiring diagram is reported in figure 2.

### Features

- LP Silicon-PYRA 04 with 5m fixed cable and open wires on the cable end, typical output 20 μV/(W/m<sup>2</sup>). Different cable lengths available upon request.

### Electrical properties.

The photodiode current signal is converted into voltage through the shunt resistance. According to the diagram 2.

### Directional sensor properties

The measurement of radiation across a surface is possible if the probe surface is a Lambert receiver. The difference between theoretical and measured response is shown in Figure 3.

The excellent concordance between the measured response and cosine law allows to use the equipment even when the sun has a very low elevation and then perform corrective actions throughout the year.

### Spectral properties

The 97% of solar energy that reaches above the atmosphere (WMO) is confined to 290nm to 3000nm spectral range. The ideal tool for measuring this radiation should have a flat response at least in this spectral range. The spectral characteristics of LP Silicon-PYRA 04 pyranometer determined primarily by the photodiode and marginally by the diffuser. The spectral response curve is shown in Figure 4, together with a typical solar spectrum.

The spectral response of LP Silicon-PYRA 04. does not cover all the solar spectrum and is not constant.

Reliable measurements can be obtained only if the LP Silicon-PYRA 04 pyranometer is calibrated with light whose spectrum is equal to the light to be measured.

Under clear sky the value of radiation measured by pyranometer has uncertainty less than 3%.

In overcast conditions, at sunrise or sunset, the solar spectrum is quite different from that used to calibrate the instrument and therefore the measurement error increases.

### Positioning

LP Silicon-PYRA 04 can be used outdoor for long periods. The probe can be fixed by two M4 threaded holes that are located on the base (Figure 5) or through the levels based LP BL.

You should take care that the diffuser surface is clean and free of deposits. If necessary, the diffuser can be washed with water and a towel for cleaning optical.

The probe can be mounted on the support LP BL (accessory) fitted level for proper placement on work surface.

N.B.: The probe is not designed to be submerged in water.

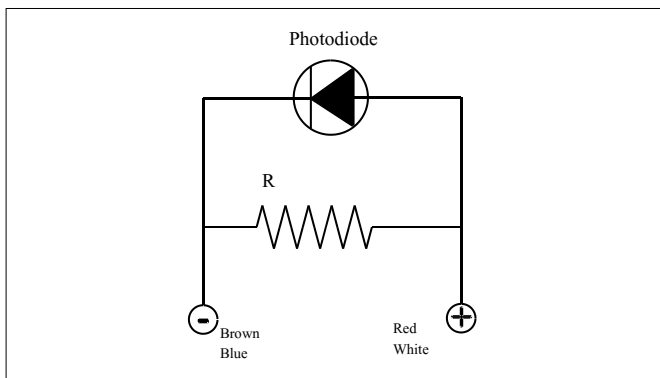

Figure 2

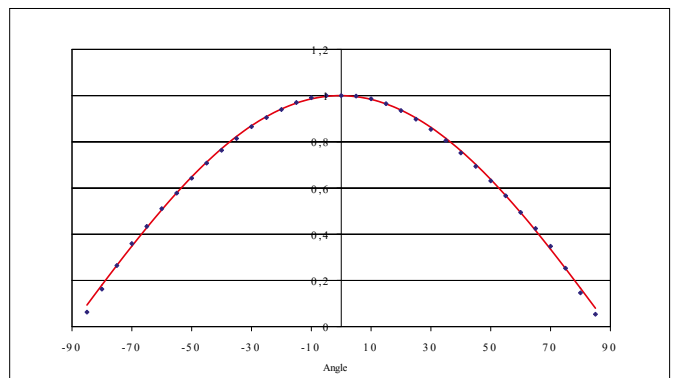

Figure 3