



PYRAsense10

A new family of pyranometers with diagnostic features and tilt sensor

INTRODUCTION

PYRAsense is our new family of pyranometers that brings solar global radiation measurement to a higher level! Depending on the model and according to ISO 9060:2018 and WMO (World Meteorological Organization) recommendations, they are classified as:

- "Spectrally Flat" Class A (High quality)
- "Spectrally Flat" Class B (Good quality)
- "Spectrally Flat" Class C (Moderate quality)

The pyranometers are based on an accurate thermopile sensor and have been designed to meet multiple needs: from the best economical solution for measuring solar efficiency (Class C) to the solution for those applications where the best possible performance is a must (Class A).

FEATURES

Internal diagnostic sensors

To measure temperature, relative humidity, and pressure. You can keep an eye on the operating condition of your pyranometer and predict any maintenance work in advance, thus always ensuring reliable measurements.

Integrated bubble level

To ease horizontal positioning during installation. Moreover, the pyranometer can be equipped with an optional tilt sensor which allows continuous monitoring of the correct installation.

Protection screen

To resist UV solar radiation.

CONFIGURATION & MEASUREMENT

The sensors

Using the PC application software DATAsense, it is possible to configure the sensor (e.g., Modbus parameters, measuring range for the analog output, etc.), monitor the measurements in real time and save the values detected during the connection in a file.

RS485 Modbus-RTU isolated output + optional additional analog output

Configurable 0...10V, 0...5V, 0...1V, 4...20 mA or 0...20 mA.

The irradiance range

It is configurable for the analog output.

Calibration report

The pyranometers are supplied factory calibrated according to ISO 9847:2023 (Type A1) standard and with an individual Calibration Report

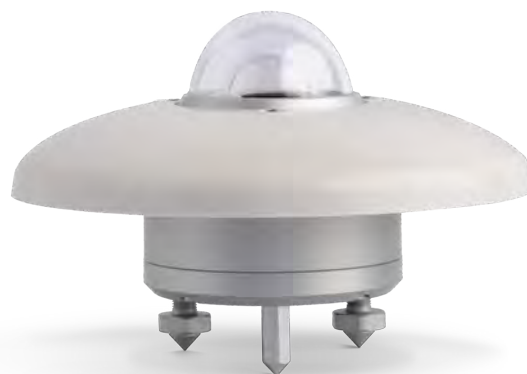

SMART TECHNOLOGY

Internal diagnostic sensors to keep operating conditions always under control



LOW MAINTENANCE

Thanks to diagnostics, you always know when you need to take actions. Average life span greater than 10 years



ACCORDING TO THE STANDARD

Spectrally Flat Class A according to ISO 9060. WMO recommendations & IEC 61724-1 requirements fully compliant



EASY TO SET UP AND QUICK TO INSTALL

Integrated bubble level and optional tilt sensor to ensure accurate installation in any position. Configuration and real time data monitoring via software



GREAT FLEXIBILITY

RS485 Modbus-RTU output galvanically isolated + optional analog output, user configurable



ACCURATE AND RELIABLE

Supplied factory calibrated with individual Calibration Report. ISO 17025 Calibration Certificate available upon request.



Technical specifications

Sensor	Thermopile
Measuring range	-200...4000 W/m ² The irradiance range for the analog output is user configurable (default 0...2000 W/m ²)
Resolution	0.1 W/m ²
Viewing angle	2π sr
Spectral range (50%)	283 ÷ 2800 nm
Output	RS485 Modbus-RTU (isolated) Optional additional analog output configurable 4...20 mA (default), 0...20 mA, 0...1 V, 0...5 V or 0...10 V
Power supply	7...30 Vdc for RS485 output 10...30 Vdc for analog output (except 0...10 V) 15...30 Vdc for 0...10 V output
Consumption	15 mA @ 24 Vdc
Connection	5-pole M12 (version with only RS485 Modbus-RTU output) 8-pole M12 (version with additional analog output)
Weight	620 g approx.
Operating conditions	-40...+80 °C / 0...100 %RH
Bubble level accuracy	< 0.2°
Protection Degree	IP 67
MTBF	> 10 years
Materials	Housing: anodized aluminium Screen: ASA Dome: optical glass

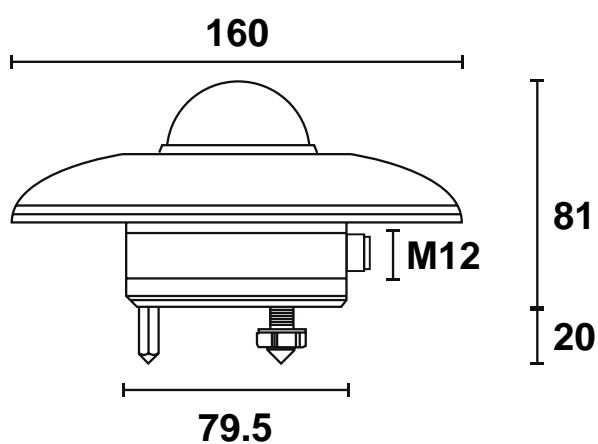

Technical specifications according to ISO 9060:2018

Response time (95%)	< 2 s	
Zero offset	a) response to a 200 W/m ² thermal radiation	< ± 7 W/m ²
	b) response to a 5 K/h change in ambient temperature	< ±2 W/m ²
	c) total zero offset including the effects a), b) and other sources	< ±10 W/m ²
Long-term instability (1 year)	< ± 0.5 %	
Non-linearity	< ± 0.2 %	
Directional response (up to 80° with 1000 W/m ² beam)	< ± 10 W/m ²	
Spectral error	< ± 0.2 %	
Temperature response (-10...+40°C)	< ± 0.5 %	
Tilt response	< ± 0.2 %	

Additional measurements

Internal Temperature	range	-40...+80 °C
	resolution	0.1 °C
	accuracy	± 0.5 °C (0...60 °C)
Internal Relative Humidity	range	0...100 %RH
	resolution	0.1%RH
	accuracy	± 3%RH @25 °C (20...80 %RH)
Internal Pressure	range	300...1100 hPa
	resolution	0.1 hPa
	accuracy	± 1 hPa (0...60 °C)
Tilt	range	0°...+180°
	resolution	0.1°
	accuracy	< 0.5°