



日揚國際事業股份有限公司
JD Auspice Co., Ltd.



Member of GHM GROUP

English

Operating manual

Pyranometers

PYRAsense

LPS02 series



Members of GHM GROUP:

GREISINGER

HONSBERG

Martens

Delta OHM

VAL.CO

note: subject to change without any notice, JDA pay no responsibility



TABLE OF CONTENTS

1 INTRODUCTION	3
2 TECHNICAL SPECIFICATIONS	4
3 MEASURING PRINCIPLE	6
4 INSTALLATION	7
4.1 OPTIONAL MOUNTING SUPPORTS	8
4.2 ELECTRICAL CONNECTIONS	9
5 CONFIGURATION	11
6 ASCII PROPRIETARY PROTOCOL	12
7 MODBUS-RTU PROTOCOL	16
8 MEASUREMENT WITH ANALOG OUTPUT (ONLY LPS02MA...)	19
9 USE OF THE DIAGNOSTIC SENSORS	20
10 MAINTENANCE	21
11 SAFETY INSTRUCTIONS	22
12 ACCESSORIES ORDERING CODES	23



1 INTRODUCTION

PYRAsense series pyranometers measure the **global irradiance** on a flat surface (W/m^2), sum of direct solar irradiance and diffuse irradiance.

The PYRAsense LPS02 series falls within the **Spectrally Flat Class B** pyranometers according to the ISO 9060:2018 standard and meets the requirements of the WMO “Guide to Instruments and Methods of Observation”.

The internal temperature, relative humidity and pressure **diagnostic sensors** allow keeping the pyranometer operating conditions under control all the time and foresee any maintenance intervention in advance, thus ensuring always reliable measurements.

The integrated bubble level and the adjustable feet facilitate horizontal positioning during installation. As option, they can be equipped with a **tilt sensor** (option T in the ordering code) which, in addition to facilitating the installation of the pyranometer, allows continuous monitoring of the correct installation. The various models are distinguished by the type of output available and by the presence or absence of the "tilt" sensor:

Model	Output		Tilt
	Digital RS485 Modbus-RTU	Analog	
LPS02M00	✓	--	--
LPS02M0T			✓
LPS02MA0	✓	Configurable 4...20 mA (default), 0...20 mA, 0...1 V, 0...5 V or 0...10 V	--
LPS02MAT			✓

The irradiance range for the analog output is user configurable (default, 0...2000W/m²).

The pyranometers are factory calibrated in accordance with the ISO 9847:2023 (Type A1) standard: "Calibration of pyranometers by comparison to a reference pyranometer". The calibration is performed by comparison with the reference sample calibrated annually at WRC (World Radiation Center).

The **DATA**sense PC application software, downloadable from the Delta OHM website, allows configuring the sensor (e.g., Modbus parameters, measuring range for the analog output, etc.), monitor the measurements in real time, even graphically for the irradiance, and save the values detected during the connection in a file.



2 TECHNICAL SPECIFICATIONS

Sensor		Thermopile
Measuring range		-200...4000 W/m ² The irradiance range for the analog output is configurable (default 0...2000 W/m ²)
Resolution		0.1 W/m ²
Viewing angle		2π sr
Spectral range (50%)		283...2800 nm
Output		RS485 Modbus-RTU (isolated) Optional additional analog output configurable 4...20 mA (default), 0...20 mA, 0...1 V, 0...5 V or 0...10 V
Power supply		7...30 Vdc for RS485 output 10...30 Vdc for analog output (except 0...10 V) 15...30 Vdc for 0...10 V output
Consumption	LPS10M0x LPS10MAX	15 mA @ 24 Vdc / 21 mA @ 12 Vdc 37 mA @ 24 Vdc & Iout=22 mA / 43 mA @ 12 Vdc & Iout=22 mA
Connection		5-pole M12 (LPS02M0x) / 8-pole M12 (LPS02MAX)
Weight		620 g approx.
Operating conditions		-40...+80 °C / 0...100 %RH / Max. altitude 6000 m
Bubble level accuracy (See specifications below for Tilt sensor accuracy)		< 0.2°
Protection degree		IP 67
Materials		Housing: anodized aluminium Screen: ASA Dome: optical glass
MTBF		> 10 years

Dimensions (mm)

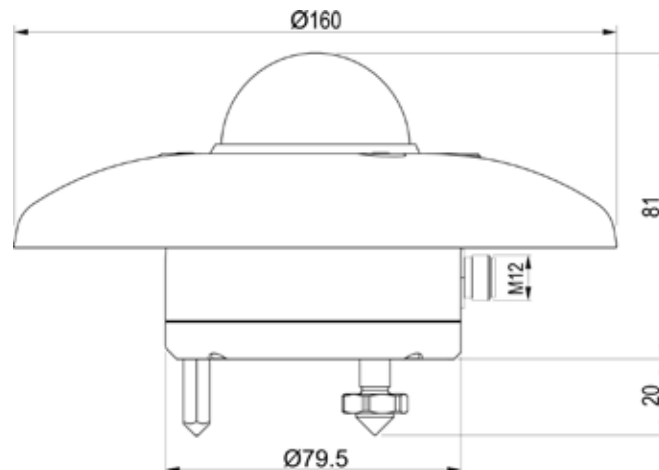

04

note: subject to change without any notice, JDA pay no responsibility



Technical Specifications According to ISO 9060:2018

Classification	Spectrally Flat Class B
Response time (95%)	< 10 s
Zero offset	
a) response to a 200 W/m ² thermal radiation	< ±10 W/m ²
b) response to a 5 K/h change in ambient temperature	< ±4 W/m ²
c) total zero offset including the effects a), b) and other sources	< ±15 W/m ²
Long-term instability (1 year)	< ±1 %
Non-linearity	< ±1 %
Directional response (up to 80° with 1000 W/m ² beam)	< ±18 W/m ²
Spectral error	< ±0.5 %
Temperature response (-10...+40°C)	< ±1.5 %
Tilt response	< ±1 %

Diagnostic sensors

Internal Temperature	
Measuring range	-40...+80 °C
Resolution	0.1 °C
Accuracy	±0.5 °C (0...60 °C)
Internal Relative Humidity	
Measuring range	0...100%
Resolution	0.1%
Accuracy	±3% @ T=25 °C & RH=20...80%
Internal pressure	
Measuring range	300...1100 hPa
Resolution	0.1 hPa
Accuracy	±1 hPa (0...60 °C)

Tilt sensor (only LPS03MxT)

Measuring range	0...180°
Resolution	0.1°
Accuracy	< 0.5°



3 MEASURING PRINCIPLE

PYRAsense series pyranometers are based on a thermopile sensor. The thermopile sensitive surface is coated with a black matt paint, which allows the pyranometer not to be selective at different wavelengths.

Radiant energy is absorbed by the thermopile black surface, thus creating a difference of temperature between the center of the thermopile (hot junction) and the pyranometer body (cold junction). Thanks to the Seebeck effect, the difference of temperature between hot and cold junction is converted into a difference of potential.

The pyranometer spectral range is determined by the transmission of the two concentric glass domes, with 50 and 30 mm outer diameters, which also grant the thermopile a proper thermal insulation from the wind and reduce the sensitivity to thermal irradiance.

Furthermore, the domes protect the thermopile from the dust which, depositing on the blackened part, could change its spectral sensitivity.

The special material used to manufacture the domes allows the spectral range to be extended to short wavelengths starting from 283 nm.

Considering a standard solar spectrum, the portion of solar irradiation detected by the pyranometer is greater than 99.8%. Figure 3.1 shows the relative spectral sensitivity of the LPS06... pyranometers (**blue line**) and the standard solar spectrum (**red line**).

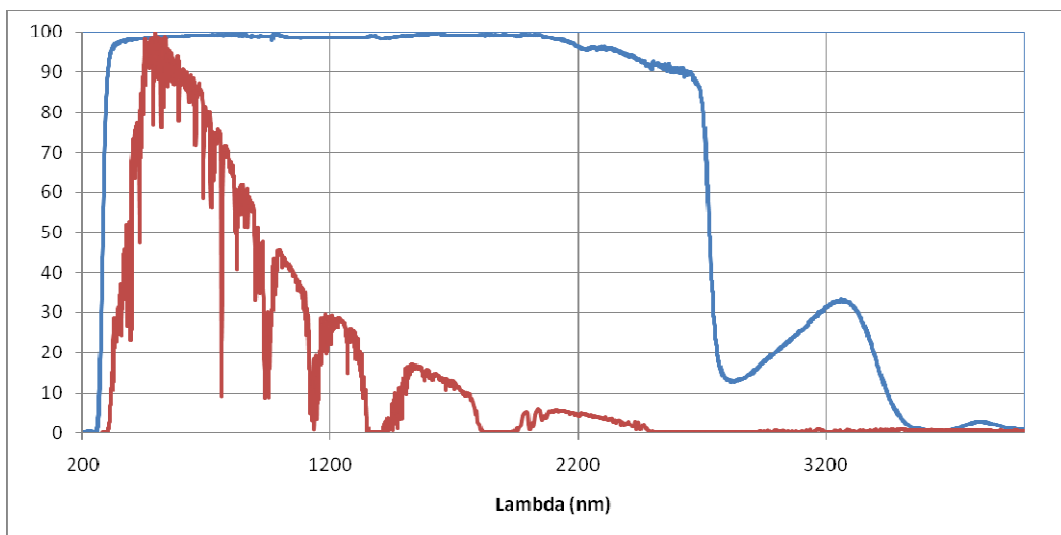

Fig. 3.1: LPS02... relative spectral sensitivity and standard solar spectrum

An internal compensation circuit minimizes the change of sensitivity with temperature. To prevent condensation from forming on the internal side of the dome under certain climatic conditions, silica-gel is inserted inside the pyranometer to absorb moisture.



4 INSTALLATION

- The pyranometer must be mounted in an easy-to-reach location in order to clean the dome regularly and carry out maintenance. At the same time, make sure that no buildings, constructions, trees or obstructions exceed the horizontal plane where the pyranometer lies. If this is not possible, select a site where obstructions in the path of the sun from sunrise to sunset do not exceed 5 degrees of elevation. **N.B.: The presence of obstructions on the horizon line affects significantly the measurement of direct irradiance.**
- The pyranometer must be located far from any kind of obstruction, which might reflect sunlight (or sun shadow) onto the pyranometer itself.
- The mast height does not exceed the pyranometer plane to avoid measurement errors caused by any reflection or shadow of the mast itself.
- In compliance with ISO TR9901 standard and WMO recommendations, if the pyranometer is used without the solar radiation protection screen, it must be positioned so that the connector points to the North Pole, if the instrument is used in the Northern Hemisphere, and to the South Pole, if used in the Southern Hemisphere. In any case, it is better to follow this recommendation even when the screen is used.
- For fixing, use the two M5 or the two M8 holes in the lower part of the pyranometer. For an accurate horizontal positioning, adjust the height of the two lower feet with knurled ring, using the bubble level integrated in the pyranometer.
 Note: for horizontal positioning it is preferable to use the bubble level also in models equipped with a tilt sensor, as it is more accurate; use the tilt sensor for positioning monitoring after installation. Use the tilt sensor for installation only if the pyranometer must be positioned tilted with respect to the horizontal plane.
- It is preferable to thermally insulate the pyranometer from its mounting bracket by securing it not with the base directly in contact with the support plate, but by leaving a layer of air in between (for this purpose, always use the feet even if the installation is not horizontal), while at the same time ensuring that there is good electrical contact to ground.

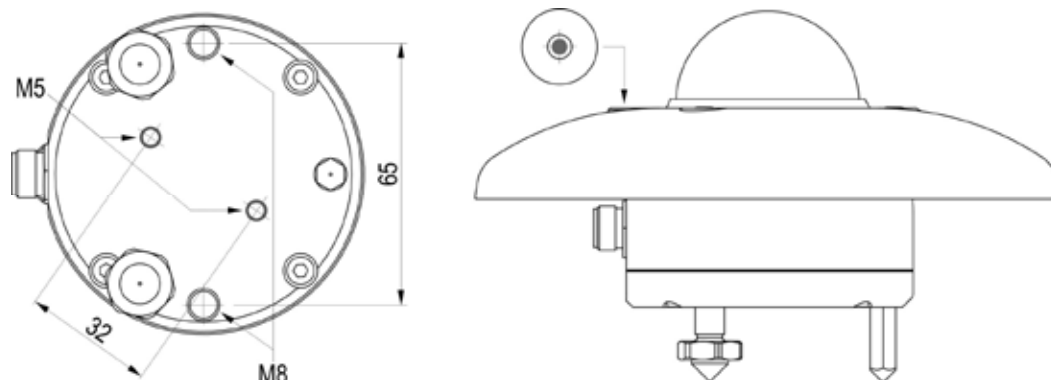

Fig. 4.1: position of fixing holes and bubble level



4.1 OPTIONAL MOUNTING SUPPORTS

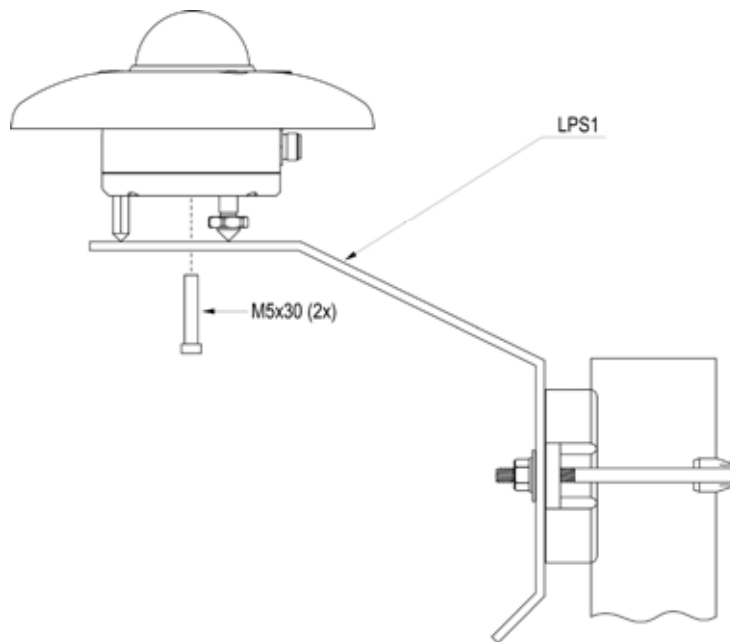

Fig. 4.2: LPS1 bracket for mast

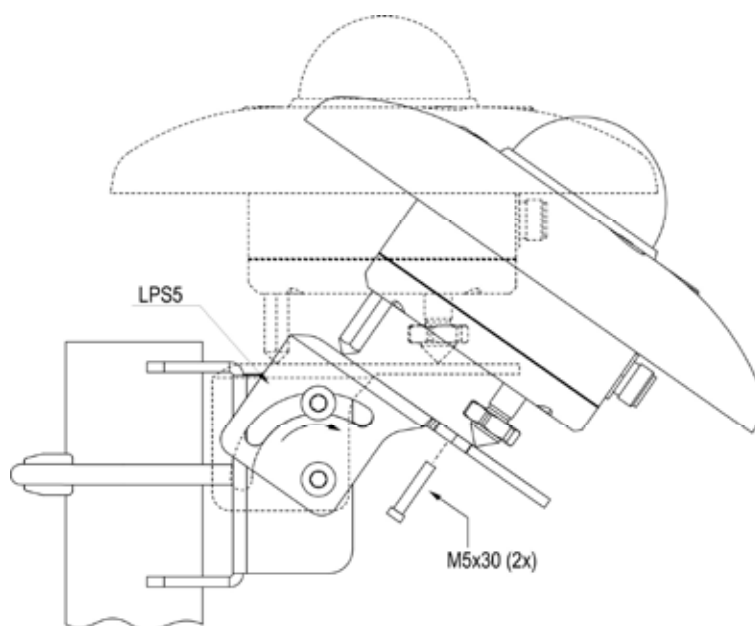

Fig. 4.3: LPS5 adjustable bracket for mast



4.2 ELECTRICAL CONNECTIONS



The metallic housing of the pyranometer should preferably be grounded (\perp) locally. In this case, do not connect the wire of the cable corresponding to the housing to prevent ground loops.

Only if it is not possible to ground locally the metallic case of the pyranometer, connect the wire of the cable corresponding to the housing to ground.

Internally there are surge protection devices connected to the housing. Grounding the housing allows the correct protection functionality of the devices.

Connector pinout:

LPS02M0x

Pin	Function	CPM12-5... wire color
1	Power supply positive (+Vdc)	Brown
2	Power supply negative (GND)	White
3	RS485 Data +	Blue
4	RS485 Data -	Black
5	Digital ground (DGND)	Grey
	Connector shell Pyranometer housing	Yellow/Green

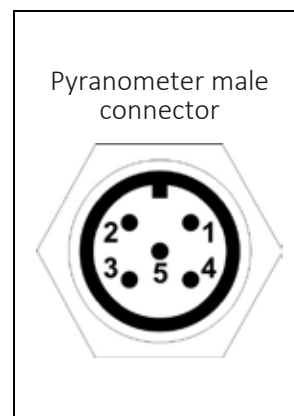

LPS02MAx

Pin	Function	CPM12-5... wire color
1	Power supply negative (GND)	White
2	Power supply positive (+Vdc)	Brown
3	Digital ground (DGND)	Green
4	RS485 Data -	Yellow
5	RS485 Data +	Grey
6	Analog ground (AGND)	Pink
7	Analog output positive (AOUT)	Blue
8	Not connected	Red
	Connector shell Pyranometer housing	Yellow/Green

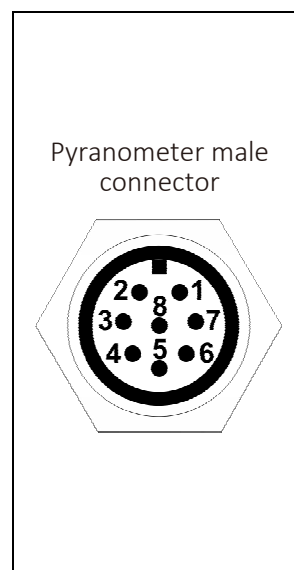

Connections:

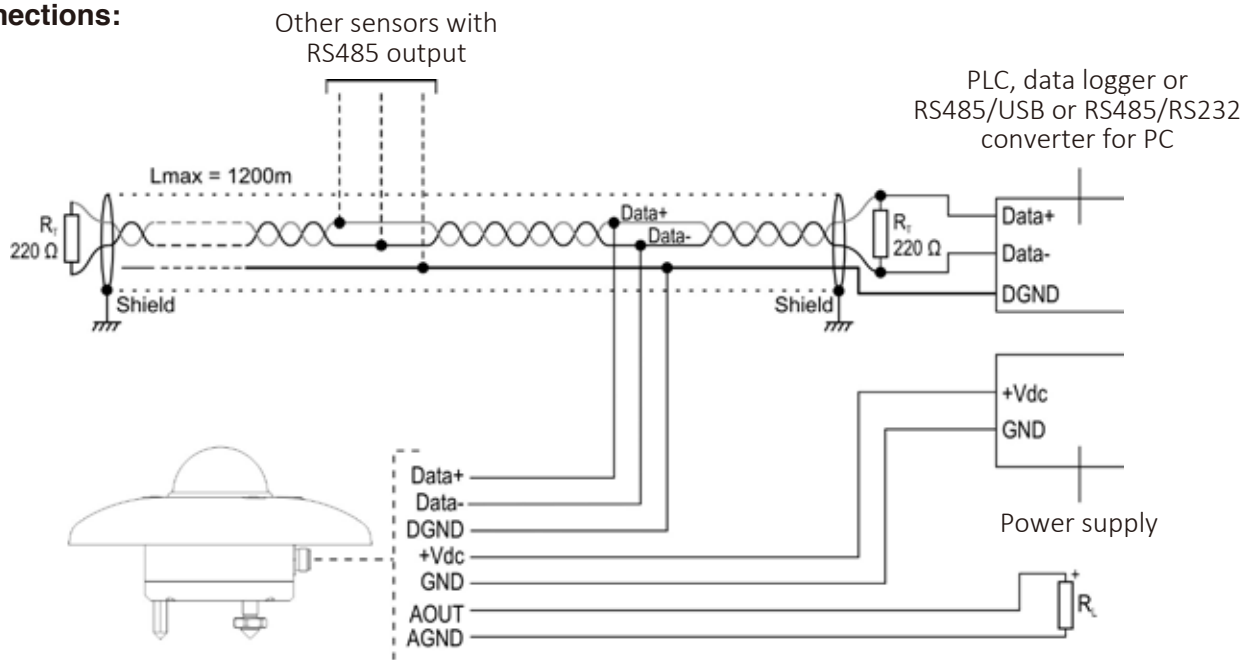

Fig. 4.4: electrical connections

RS485 output:

The RS485 output is isolated. Before connecting the pyranometer to the RS485 network, set the address and the communication parameters, if different from the factory preset (see “Configuration” chapter).

Analog output:

In the LPS02MAx models the type of analog output is configurable (default 4...20 mA, see “Configuration” chapter). The pyranometer power supply and the load resistance vary according to the type of analog output configured:

Analog output	Power supply required	Load resistance
0...20 mA	10...30 Vdc	≤ 500 Ω
4...20 mA	10...30 Vdc	≤ 500 Ω
0...1 V	10...30 Vdc	≥ 100 kΩ
0...5 V	10...30 Vdc	≥ 100 kΩ
0...10 V	15...30 Vdc	≥ 100 kΩ

In the event of an anomaly in the measurement (detected measurement outside the measuring range), the output goes to a value 10% higher than the full scale (e.g., 11 V if the output is 0...10 V or 22 mA if the output is 4...20 mA).



5 CONFIGURATION

It is possible to change the serial communication parameters (Modbus address, Baud Rate, parity/stop bit) and, for models with analog output, the type of analog output and the global irradiance measuring range corresponding to the analog output.

The configuration of the pyranometer can be done:

- With the aid of **DATAsense** PC application software (see the software online help), downloadable from Delta OHM website.
- By sending serial commands from a PC, via a standard communication program (see the chapter “ASCII proprietary protocol”).
- Via the “Holding Registers” in MODBUS-RTU mode (only for the serial communication parameters, see the chapter “Modbus-RTU protocol”).

By default, the instrument has MODBUS address **1** and communication parameters 19200, 8E1.

Analog output (only LPS02MAx):

By default, the analog output is 4...20 mA → 0...2000 W/m².

It is possible:

- to associate the analog output to a different global irradiance range, within the full measuring range;
- change the output type (possible outputs 4...20 mA, 0...20 mA, 0...1 V, 0...5 V or 0...10 V);
- to reverse the direction of the output, so that the output decreases as the measurement increases.

Connection to PC:

To connect the pyranometer to a PC USB port, to check or change the configuration, the **CP24B-5** (LPS02M0x) or **CP24B-8** (LPS02MAx) optional cables can be used, which also allow the pyranometer to be powered via the USB port.

To use the CP24B-x cables, the related USB drivers must be installed in the PC.

Alternatively, it is possible to use a standard RS485/USB or RS485/RS232 converter, powering the pyranometer separately (the minimum supply voltage is 7 V).



6 ASCII PROPRIETARY PROTOCOL

To communicate with the pyranometer via the ASCII proprietary protocol:

1. Connect the pyranometer to the PC and start a standard serial communication program.
2. In the serial communication program, set the Baud Rate 57600, the parameters 8N2 and the COM port number to which the pyranometer is connected.
3. Power the pyranometer (or power cycle if already powered) and send the command @ within 5 seconds from the instrument power on (the pyranometer replies &I if the command @ is recognized).
Note: if the CP24B-x cable is used, to power cycle the pyranometer, disconnect the cable for a few seconds from the PC USB port, then reconnect it.
4. Send the command **CAL USER ON** (the pyranometer replies CAL USER ON;USER ON) to enable the configuration change. The command CAL USER ON is not required only for reading the settings.
5. Send the commands described in the tables below.

The command CAL USER ON is automatically disabled after a few minutes of inactivity. The command CAL USER ON can be disabled immediately by sending the command CAL EXIT.

Ping:

Command	Reply	Description
P0	P0;&	Ping.

Pyranometer general information:

Command	Reply	Description
G0	G0;model	Model
G1	G1;sub-model	Sub-model
G2	G2;nnnnnnnn	Serial number
G3	G3;xx.yy	Firmware revision
G4	G4;aaaa/mm/gg	Firmware revision date
G5	G5;xx.yy	Hardware revision
G6	G6;nnnnn	Operating time in days from first power on
G7	G7;nnnnn	Operating time in days from last power on
GD	GD;aaaa/mm/gg hh:mm:ss	Factory calibration date and time

User code:

The user code is an alphanumeric string of up to 8 characters that the user can set to identify the pyranometer with a mnemonic name.

Command	Reply	Description
CUCnnnnnnnn	CUC;&	Sets nnnnnnnn as user code. Default=blank
RUC	RUC;nnnnnnnn	Reads the user code.



RS485 Modbus-RTU communication parameters:

Command	Reply	Description
CMA _n	CMA;&	Sets the Modbus-RTU address (1...247) to n. Default=1
RMA	RMA;n	Reads the Modbus-RTU address.
CMB _n	CMB;&	Sets the Baud Rate: <ul style="list-style-type: none"> • 9600 if n=0 • 19200 if n=1 (default) • 38400 if n=2 • 57600 if n=3 • 115200 if n=4
RMB	RMB;n	Reads Baud Rate setting.
CMP _n	CMP;&	Sets parity and stop bits (data bits = 8 fixed): <ul style="list-style-type: none"> • 8N1 if n=0 • 8E1 if n=2 (default) • 8O1 if n=4 • 8N2 se n=1 • 8E2 se n=3 • 8O2 se n=5
RMP	RMP;n	Reads the setting of parity and stop bits.
CMW _n	CMW;&	Sets waiting time after transmission with Modbus-RTU protocol: <ul style="list-style-type: none"> • Immediate reception if n=0 (violates protocol) • Waiting 3.5 characters if n=1 (respects protocol) Default : Waiting 3.5 characters (n=1)
RMW	RMW;n	Reads the setting of waiting time after transmission with Modbus-RTU protocol.

Analog output (only LPS02MA...):

Command	Reply	Description
CAS _n	CAS;&	Sets the analog output type: <ul style="list-style-type: none"> • 0...20 mA if n=0 • 4...20 mA if n=1 (default) • 0...1 V if n=2 • 0...5 V if n=3 • 0...10 V if n=4
RAS	RAS;n	Reads the type of analog output set.
CAIn _{nnn}	CAI;&	Sets nnnn as irradiance minimum value in W/m ² for the analog output. Min=-200, default=0
RAI	RAI;nnnn	Reads the irradiance minimum value in W/m ² for the analog output.
CAF _{nnnn}	CAF;&	Sets nnnn as irradiance maximum value in W/m ² for the analog output. Max=4000, default=2000
RAF	RAF;nnnn	Reads the irradiance maximum value in W/m ² for the analog output.
CAi _n	CAi;&	Sets the direct or reversed correspondence between analog output and irradiance: <ul style="list-style-type: none"> • If n=0: Min. output → Min. irradiance Max. output → Max. irradiance • If n=1: Min. output → Max. irradiance Max. output → Min. irradiance Default : Direct correspondence (n=0)
RAi	RAi;n	Reads the type of correspondence (direct or reversed) between analog output and irradiance.



Units of measurement:

Changing the temperature units of measurement affects the Modbus protocol only. The temperature measurement provided by the ASCII proprietary protocol (commands S0/S1) is always in °C.

Command	Reply	Description
TTn	WUT;&	Sets the temperature unit of measurement: <ul style="list-style-type: none"> • °C if n=0 (default) • °F if n=1 • K if n=2
RUT	RUT;n	Reads the temperature unit of measurement.

Measurements reading:

Command	Reply	Description
S0	S0;meas	Prints the measurements in the following sequence: <ul style="list-style-type: none"> • Temperature compensated irradiance in W/m² <i>(it takes into account the change in sensor sensitivity as temperature changes)</i> • Nominal irradiance in W/m² <i>(calculated considering the sensor nominal sensitivity at the calibration temperature:~23 °C)</i> • Signal in mV generated by the thermopile • Internal temperature in °C • Internal relative humidity in % • Internal pressure in hPa • Tilt angle <i>(only LPS04MxT)</i> • Power supply voltage If the automatic sending of the measurements is enabled (command S1), sending S0 disables the automatic sending.
S1	S1;meas	Enables the automatic sending of the measurements, once per second.

Diagnostics alarm thresholds:

Command	Reply	Description
WAL1n...n	WAL1;&	Sets to n...n the operating time alarm threshold from first power on (0...65535 days, default=730 days → 2 years).
AL1	AL1;n...n	Reads the operating time alarm threshold from first power on.
WAL2n...n	WAL2;&	Sets to n...n the operating time alarm threshold from last power on (0...65535 days, default=730 days → 2 years).
AL2	AL2;n...n	Reads the operating time alarm threshold from last power on.
WAL3n...n	WAL3;&	Sets to n...n, in the set unit of measurement, the internal temperature alarm threshold (0...150 °C, default=80°C).
AL3	AL3;n...n	Reads the internal temperature alarm threshold.
WAL4n...n	WAL4;&	Sets to n...n% the internal relative humidity alarm threshold (0...100%, default=25%).
AL4	AL4;n...n	Reads the internal relative humidity alarm threshold.



Command	Reply	Description
WAL5n...n	WAL5;&	Sets to n...n hPa the internal pressure alarm threshold (800...1100 hPa, default=1100 hPa).
AL5	AL5;n...n	Reads the internal pressure alarm threshold.

All alarm thresholds are integer values with resolution 1 (1 day, 1 °C/°F/K, 1 %RH, 1hPa).
The alarm condition occurs when the parameter becomes greater than the set threshold.



7 MODBUS-RTU PROTOCOL

By default, the pyranometer has Modbus address 1 and communication parameters 19200, 8E1. The address and the communication parameters can be changed by using the appropriate serial commands of the proprietary protocol or, alternatively, directly with Modbus commands by changing the value of the Holding Registers described later.

The Modbus-RTU protocol is active after a few seconds from the sensor power on.

The delay between the reception of a query from the master device and the start of the pyranometer reply is less than 10 ms.

Below is the list of registers.

Input Registers:

Address	Description	Format
MEASUREMENTS		
1	Temperature compensated irradiance in W/m ² (x10) (it takes into account the change in sensor sensitivity as temperature changes)	32-bit Integer
3	Nominal irradiance in W/m ² (x10) (calculated considering the sensor nominal sensitivity at the calibration temperature:~23 °C)	32-bit Integer
6	Internal relative humidity in % (x10)	16-bit Integer
7	Internal temperature in the set unit of measurement (x10)	16-bit Integer
8	Internal pressure in hPa (x10)	16-bit Integer
9	Signal in mV generated by the thermopile (x1000)	32-bit Integer
11	Tilt angle (only LPS02MxT) (x10)	16-bit Integer
PYRANOMETER GENERAL INFORMATION		
16...25	Model (20 characters)	String
26...35	Sub-model (20 characters)	String
36...39	Serial number (8 characters)	String
40...43	Firmware revision (8 characters)	String
44...47	Hardware revision (8 characters)	String
CALIBRATION HISTORY		
50	Sensitivity of last calibration in μV/Wm ⁻² (x1000)	32-bit Integer
52...55	Date of last calibration (yyyymmdd)	String
56	Sensitivity of historical calibration 1 in μV/Wm ⁻² (x1000)	32-bit Integer
58...61	Date of historical calibration 1 (yyyymmdd)	String
62	Sensitivity of historical calibration 2 in μV/Wm ⁻² (x1000)	32-bit Integer
64...67	Date of historical calibration 2 (yyyymmdd)	String
68	Sensitivity of historical calibration 3 in μV/Wm ⁻² (x1000)	32-bit Integer
70...73	Date of historical calibration 3 (yyyymmdd)	String
74	Sensitivity of historical calibration 4 in μV/Wm ⁻² (x1000)	32-bit Integer



Address	Description	Format
76...79	Date of historical calibration 4 (yyyymmdd)	String
80	Sensitivity of historical calibration 5 in $\mu\text{V}/\text{Wm}^{-2}$ (x1000)	32-bit Integer
82...85	Date of historical calibration 4 (yyyymmdd)	String
OPERATING TIME		
100	Operating time in days from first power on	16-bit Integer
101	Operating time in days from last power on	16-bit Integer

Notes on the registers format:

1) To read a **32-bit integer** value, two consecutive registers starting from the one indicated must be accessed. The register with lower address contains the most significant bits.

Example: the temperature compensated irradiance, for ex. 50.1 W/m², is available in the registers with address 1 and 2.

Register address	1	2
Register content (Hex)	0000	01F5
Read value	0x000001F5 = 501 = 50.1 W/m ²	

2) The alphanumeric **strings** are contained in a series of 16-bit registers. Each register contains 2 characters of the string: the most significant 8 bits contain the ASCII code of the first character, the least significant 8 bits contain the ASCII code of the next character. The start character of the string is in the register of the series with the lowest address.

Example: the pyranometer model, for ex. LPS02MAT, is available in the registers with address from 16 to 25.

Register address	16	17	18	19	20	21	22	23	24	25
Register content (Hex)	4C50	5331	304D	4154	0000	0000	0000	0000	0000	0000
Read value	L	P	S	1	0	M	A	T		

Discrete inputs:

Address	Description	Format
0	Operating time alarm from first power on	Bit
1	Operating time alarm from last power on	Bit
2	Internal temperature alarm	Bit
3	Internal relative humidity alarm	Bit
4	Internal pressure alarm	Bit

The value of a "Discrete input", normally at 0, becomes 1 when the alarm threshold set with the relative "Holding register" is exceeded.



Discrete inputs:

Address	Description	Format
0	RS485 Modbus-RTU Baud Rate: 0=9600 1=19200 (default) 2=38400 3=57600 4=115200	16-bit Integer
1	RS485 Modbus-RTU parity and stop bits: 0=8N1 1=8N2 2=8E1 (default) 3=8E2 4=8O1 5=8O2	16-bit Integer
2	Modbus-RTU address (1...247, default=1).	16-bit Integer
5	Temperature unit of measurement: 0=°C (default) 1=°F 2=K	16-bit Integer
6	Operating time alarm threshold from first power on (0...65535 days, default=730 days → 2 years)	16-bit Integer
7	Operating time alarm threshold from last power on (0...65535 days, default=730 days → 2 years)	16-bit Integer
8	Internal temperature alarm threshold in the set unit of measurement (0...150 °C, default=80 °C)	16-bit Integer
9	Internal relative humidity alarm threshold in % (0...100 %, default=25%)	16-bit Integer
10	Internal pressure alarm threshold in hPa (800...1100 hPa, default=1100 hPa)	16-bit Integer

All alarm thresholds are integer values with resolution 1 (1 day, 1 °C/°F/K, 1 %RH, 1hPa).



8 MEASUREMENT WITH ANALOG OUTPUT (only LPS02MA...)

Calculation of the global irradiance E_e (W/m^2) as a function of the analog output value V_{out} (in V) or I_{out} (mA).

Analog output	Global irradiance
0...20 mA	$E_e = E_{is} + [(E_{fs} - E_{is}) \cdot I_{out}/20]$
4...20 mA	$E_e = E_{is} + [(E_{fs} - E_{is}) \cdot (I_{out} - 4)/16]$
0...1 V	$E_e = E_{is} + [(E_{fs} - E_{is}) \cdot V_{out}/20]$
0...5 V	$E_e = E_{is} + [(E_{fs} - E_{is}) \cdot V_{out}/5]$
0...10 V	$E_e = E_{is} + [(E_{fs} - E_{is}) \cdot V_{out}/10]$

Where E_{is} and E_{fs} are respectively the global irradiance (in W/m^2) corresponding to the analog output initial and full scale.

Considering the default values $E_{is} = 0$ and $E_{fs} = 2000 W/m^2$, the previous formulas can be simplified into the following ones:

Analog output	Global irradiance
0...20 mA	$E_e = 100 \cdot I_{out}$
4...20 mA	$E_e = 125 \cdot (I_{out} - 4)$
0...1 V	$E_e = 2000 \cdot V_{out}$
0...5 V	$E_e = 400 \cdot V_{out}$
0...10 V	$E_e = 200 \cdot V_{out}$



9 USE OF THE DIAGNOSTIC SENSORS

The internal temperature, relative humidity, pressure and tilt (only LPS02MxT) **diagnostic sensors** allow keeping the pyranometer operating conditions under control all the time and foresee any maintenance intervention in advance, thus ensuring always reliable measurements.

Internal temperature

As a rule, the internal temperature of the pyranometer is on average 5 to 10 °C higher than the external ambient temperature. Temperatures that are excessively lower or higher than indicated may be a sign of malfunctions.

Monitoring the internal temperature therefore makes it possible to determine whether the irradiance measurement can be considered reliable.

Internal relative humidity

To minimize condensation and keep measurements accurate, desiccant silica-gel is provided inside the pyranometer base to absorb moisture. The silica-gel life is at least 10 years. The long-term monitoring of the internal relative humidity of the pyranometer allows the efficiency of the silica-gel to be checked. A progressive upward trend in relative humidity indicates the progressively decreasing ability of silica-gel to absorb moisture.

The internal relative humidity depends not only on the saturation level of the silica-gel but also on the temperature of the pyranometer; therefore, short-term humidity monitoring is not particularly significant in determining the condition of the silica-gel. Relative humidity monitoring can be annual. It is advisable to detect the relative humidity during the night, when the temperature is lower and the relative humidity is higher.

Silica-gel can be considered close to saturation when the internal relative humidity is persistently above 50% at temperatures below 20 °C.

Internal pressure

Monitoring the internal pressure of the pyranometer allows the housing to be checked for tight seal (no leakage). The pressure/temperature ratio should remain approximately constant.

Tilt

Monitoring the inclination angle of the pyranometer installation allows for the detection of unwanted displacements that may occur in the long term or as a result of impacts suffered by the installation. Take the measurement of the Tilt sensor immediately after installation and consider it as a reference for subsequent measurements.

Alarm thresholds

Thresholds can be defined for internal temperature, relative humidity and pressure.

When the thresholds are exceeded an alarm condition is generated, which can be read via the Modbus “Discrete inputs” or the DATAsense software.

The thresholds can be set via the Modbus “Holding registers”, the WAL3/WAL4/WAL5 serial commands or the DATAsense software.



10 MAINTENANCE

In order to grant measurements high accuracy, it is important to keep the outer glass dome clean. Consequently, the more the dome will be kept clean, the more measurements will be accurate. You can wash it using water and standard papers for lens. If necessary, use pure ETHYL alcohol. After using alcohol, clean again the dome with water only.

To minimize condensation and keep measurements accurate, desiccant silica-gel is provided inside the pyranometer base to absorb moisture. The silica-gel life is at least 10 years and can be replaced by the user.

To replace the silica-gel, unscrew the 4 screws that fix the base to the main body of the pyranometer; remove the silica-gel sachet and insert a new sachet, then screw the pyranometer base back on.

Warning: the silica-gel replacement must be done in an ESD-safe environment.

To exploit all the pyranometer features, it is highly recommended that the calibration be checked annually.

The pyranometer provides the operating time in days since first and last power on, and allows time alarm thresholds to be set to alert the user of the need for periodic verification or maintenance.

The exceeding of thresholds can be read via Modbus "Discrete inputs" or DATAsense software.

The thresholds can be set via Modbus "Holding registers", WAL1/WAL2 serial commands, or DATAsense software.



11 SAFETY INSTRUCTIONS

The pyranometer proper operation and operating safety can be ensured only in the climatic conditions specified in this manual and if all standard safety measures as well as the specific measures described in this manual are followed.

Do not use the instruments in places where there are:

- Corrosive or flammable gases.
- Direct vibrations or shocks to the instrument.
- High-intensity electromagnetic fields, static electricity.

User obligations

The instrument operator shall follow the directives and regulations below that refer to the treatment of dangerous materials:

- EU directives on workplace safety.
- National law regulations on workplace safety.
- Accident prevention regulations.



12 ACCESSORIES ORDERING CODES

The pyranometer is supplied with solar radiation protection screen, M12 female free connector (only if the optional cable is not ordered), calibration report and PC application software downloadable from Delta OHM website.

Cables and fixing accessories must be ordered separately.

Fixing accessories

- LPS1** Fixing bracket for \varnothing 40...50 mm mast. Installation on horizontal or vertical mast.
- LPS5** Adjustable holder for mounting the pyranometer in an inclined position on \varnothing 40...50 mm mast.

Installation cables

- CPM12-5...** Cable with 5-pole M12 connector on one end, open wires on the other end. Length 5 m (CPM12-5.5) or 10 m (CPM12-5.10). **For LPS02M0...**
- CPM12-8...** Cable with 8-pole M12 connector on one end, open wires on the other end. Length 5 m (CPM12-8.5) or 10 m (CPM12-8.10). **For LPS02MA...**

PC connecting cables

- CP24B-5** PC connecting cable for the configuration of the pyranometer. With built-in RS485/USB converter. 5-pole M12 connector on sensor side and A-type USB connector on PC side. **For LPS02M0...**
- CP24B-8** PC connecting cable for the configuration of the pyranometer. With built-in RS485/USB converter. 8-pole M12 connector on sensor side and A-type USB connector on PC side. **For LPS02MA...**

Spare parts

- LPSP1A** UV-resistant solar radiation protection screen.
- LPG** Silica-gel (5 sachets).

DELTA OHM metrology laboratories LAT N° 124 are ISO/IEC 17025 accredited by ACCREDIA for Temperature, Humidity, Pressure, Photometry / Radiometry, Acoustics and Air Velocity. They can supply calibration certificates for the accredited quantities.



WARRANTY

Delta OHM is required to respond to the "factory warranty" only in those cases provided by Legislative Decree 6 September 2005 - n. 206. Each instrument is sold after rigorous inspections; if any manufacturing defect is found, it is necessary to contact the distributor where the instrument was purchased from. During the warranty period (24 months from the date of invoice) any manufacturing defects found will be repaired free of charge. Misuse, wear, neglect, lack or inefficient maintenance as well as theft and damage during transport are excluded. Warranty does not apply if changes, tampering or unauthorized repairs are made on the product. Solutions, probes, electrodes and microphones are not guaranteed as the improper use, even for a few minutes, may cause irreparable damages.

Delta OHM repairs the products that show defects of construction in accordance with the terms and conditions of warranty included in the manual of the product. For any dispute, the competent court is the Court of Padua. The Italian law and the "Convention on Contracts for the International Sales of Goods" apply.

TECHNICAL INFORMATION

The quality level of our instruments is the result of the continuous product development. This may lead to differences between the information reported in the manual and the instrument you have purchased. In case of discrepancies and/or inconsistencies, please write to sales@deltaohm.com. Delta OHM reserves the right to change technical specifications and dimensions to fit the product requirements without prior notice.

DISPOSAL INFORMATION

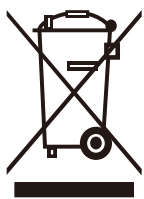

Electrical and electronic equipment marked with specific symbol in compliance with 2012/19/EU Directive must be disposed of separately from household waste. European users can hand them over to the dealer or to the manufacturer when purchasing a new electrical and electronic equipment, or to a WEEE collection point designated by local authorities. Illegal disposal is punished by law.

Disposing of electrical and electronic equipment separately from normal waste helps to preserve natural resources and allows materials to be recycled in an environmentally friendly way without risks to human health.

